

1/2" LOCK NUTS NOT SHOWN ON END VIEWS FOR CLARITY.

OUTPUT OPTION	OUTPUT	SUPPLY	
A	0.5 TO 4.5V RATIOMETRIC	5V	} BUFFERED
C	0.5 TO 9.5V	24V	
G	0.5 TO 4.5V	24V	
H	4 TO 20mA	24V	

SUPPLY CURRENT 12mA TYP. 20mA MAX. PLUS O/P CURRENT

CABLE: 0.2mm<sup>2</sup>, O/A SCREEN, PUR JACKET – SUPPLIED WITH 50cm OR REQUIRED LENGTH IN cm. e.g. 'L50'  
3-CORE: JACKET Ø4mm

CABLE/CONNECTOR\* CONNECTIONS;

CABLE	CONNECTOR	
RED	:1	+Ve
BLACK	:3	0V
WHITE	:2	OUTPUT
SCREEN	:4	BODY

\*CONNECTORS; MAXIMUM CONDUCTOR CROSS SECTION 0.75mm<sup>2</sup>  
RANGE OF DISPLACEMENT FROM 0–5mm TO 0–50mm e.g.36, IN INCREMENTS OF 1mm.  
BODY MATERIAL: STAINLESS STEEL.

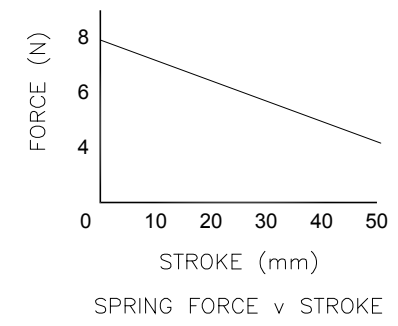
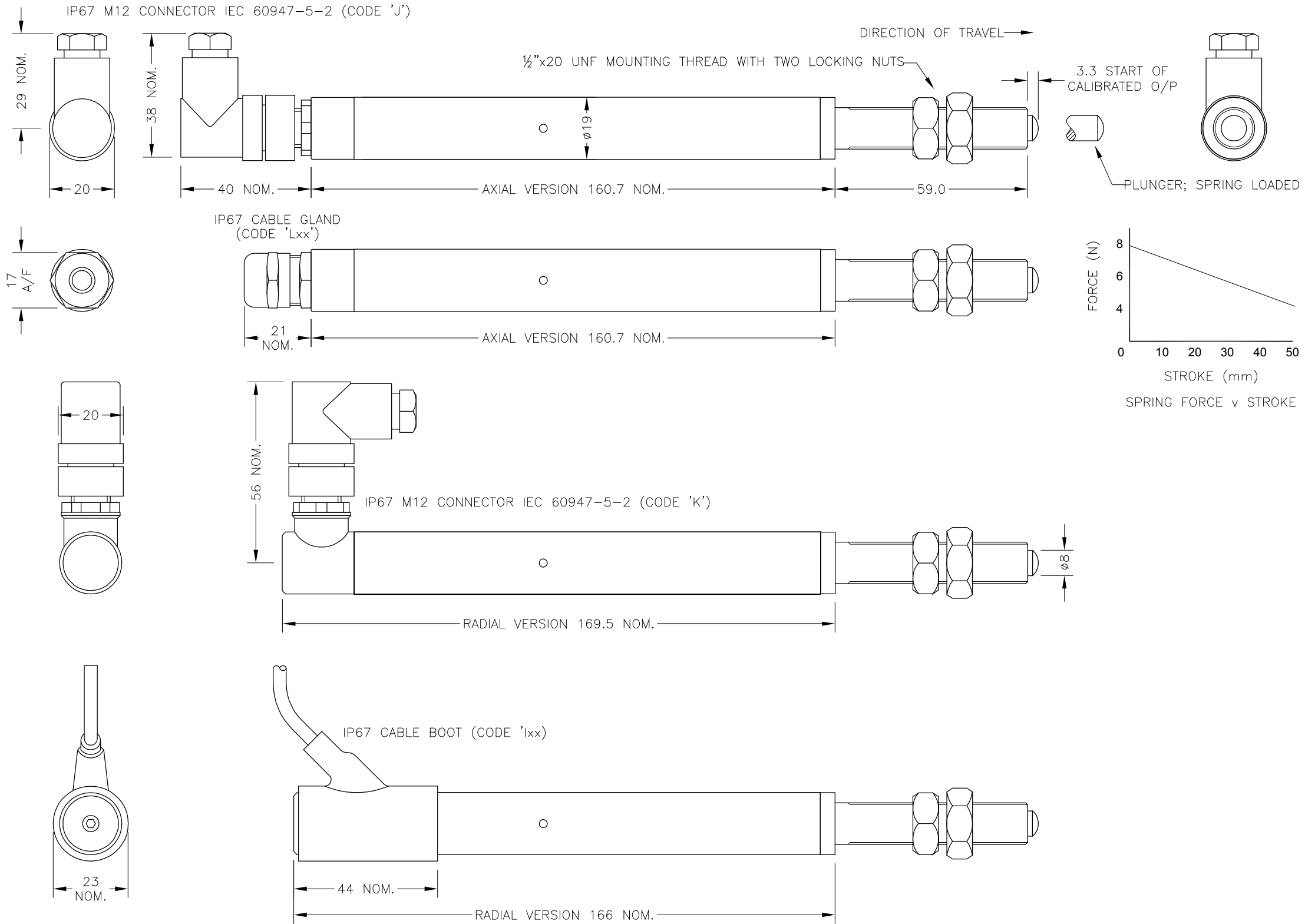

H	OPTION J IP67 CONN.	PDM
J	RANGE WAS 10-50mm RAN1056	RDS
K	RANGE NOTE AMENDED ~ RAN1200	PDM
L	4 TO 20mA ADDED RAN1256	RDS



DRAWINGS NOT TO BE CHANGED WITHOUT REFERENCE TO THE CHANGE PROCEDURE.  
CHANGES TO PARTS USED IN INTRINSICALLY SAFE PRODUCT MUST BE APPROVED BY THE AUTHORISED PERSON  
THIS IS AN UNCONTROLLED PRINT AND WILL NOT BE UPDATED.

THE PLUNGER WILL RETRACT FLUSH AND EXTENDS 2mm NOM. AT END OF CALIBRATED TRAVEL.

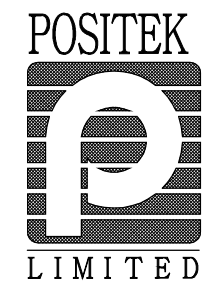

H	04/05/12		CHECKED BY	X	±0.4
J	9/11/15		X.X	±0.2	
K	05/09/17		X.XX	±0.1	
L	05/09/18				DIMS mm
		DESCRIPTION			
		P112 LIPS GAUGE HEAD POSITION SENSOR			
SCALE 12.5mm		DRAWING NUMBER P112-11		REV	L
				SHEET 1 OF 1	

# LIPS<sup>®</sup> P112 GAUGE HEAD POSITION SENSOR

Position feedback for industrial and scientific applications

- Gauge head positioning for industrial and scientific applications
- Non-contacting inductive technology to eliminate wear
- Travel set to customer's requirement
- Compact 19 mm diameter body
- Sealing to IP67

As a leading designer and manufacturer of linear, rotary, tilt and intrinsically safe position sensors, Positek<sup>®</sup> has the expertise to supply a sensor to suit a wide variety of applications.

Our P112 LIPS<sup>®</sup> (Linear Induction Position Sensor) is an affordable, durable high-accuracy sensor for gauge head positioning in industrial and scientific applications. The P112, like all Positek<sup>®</sup> sensors, provides a linear output proportional to travel. Each sensor is supplied with the output calibrated to the travel required by the customer, from 5mm to 50mm and with full EMC protection built in.

It is particularly suitable for OEMs seeking good sensor performance for arduous applications such as industrial machinery where cost is important.

Overall performance, repeatability and stability are outstanding over a wide temperature range. The sensor is very robust, the body and plunger being made of stainless steel for long service life and environmental resistance.

The plunger is spring loaded with a domed end. The P112 is easy to install with a long ½ inch UNF mounting thread and is supplied with two lock nuts for positioning. Environmental sealing is to IP67.



## SPECIFICATION

<b>Dimensions</b>	
Body diameter	19 mm
Body Length (excluding thread)	
(Axial version)	160.7 mm
(Radial version)	166 mm cable
(Radial version)	169.5 mm connector
Mounting Thread Length	59 mm
For full mechanical details see drawing P112-11	
<b>Spring Force</b>	1.5 - 4.5 N approx.
<b>Independent Linearity</b>	≤ ± 0.25% FSO @ 20°C
	≤ ± 0.1% FSO @ 20°C* available upon request.
*Sensors with calibrated travel of 10 mm and above.	
<b>Temperature Coefficients</b>	< ± 0.01%/°C Gain & < ± 0.01%FS/°C Offset
<b>Frequency Response</b>	> 10 kHz (-3dB)
<b>Resolution</b>	Infinite
<b>Noise</b>	< 0.02% FSO
<b>Environmental Temperature Limits</b>	
Operating	-40°C to +125°C standard -20°C to +85°C buffered -40°C to +125°C
Storage	
Sealing	IP67
<b>EMC Performance</b>	EN 61000-6-2, EN 61000-6-3
<b>Vibration</b>	IEC 68-2-6: 10 g
<b>Shock</b>	IEC 68-2-29: 40 g
<b>MTBF</b>	350,000 hrs 40°C Gf
<b>Drawing List</b>	
P112-11	Sensor Outline
Drawings, in AutoCAD <sup>®</sup> dwg or dxf format, available on request.	

Do you need a position sensor made to order to suit a particular installation requirement or specification? We'll be happy to modify any of our designs to suit your needs - please contact us with your requirements.

# LIPS<sup>®</sup> P112 GAUGE HEAD POSITION SENSOR

Position feedback for industrial and scientific applications

## How Positek's PIPS<sup>®</sup> technology eliminates wear for longer life

Positek's PIPS<sup>®</sup> technology (Positek Inductive Position Sensor) is a major advance in displacement sensor design. PIPS<sup>®</sup>-based displacement transducers have the simplicity of a potentiometer with the life of an LVDT/RVDT.

PIPS<sup>®</sup> technology combines the best in fundamental inductive principles with advanced micro-electronic integrated circuit technology. A PIPS<sup>®</sup> sensor, based on simple inductive coils using Positek's ASIC control technology, directly measures absolute position giving a DC analogue output signal. Because there is no contact between moving electrical components, reliability is high and wear is eliminated for an exceptionally long life.

PIPS<sup>®</sup> overcomes the drawbacks of LVDT technology – bulky coils, poor length-to-stroke ratio and the need for special magnetic materials. It requires no separate signal conditioning.

Our LIPS<sup>®</sup> range are linear sensors, while RIPS<sup>®</sup> are rotary units and TIPS<sup>®</sup> are for detecting tilt position. Ask us for a full technical explanation of PIPS<sup>®</sup> technology.

We also offer a range of ATEX-qualified intrinsically-safe sensors.

## TABLE OF OPTIONS

**CALIBRATED TRAVEL:** Factory set to any length from 0-5mm to 0-50mm (e.g. 36mm).

### ELECTRICAL INTERFACE OPTIONS

OUTPUT SIGNAL	SUPPLY INPUT	OUTPUT LOAD
Standard:		
0.5-4.5V dc ratiometric	+5V dc nom. ± 0.5V.	5kΩ min.
Buffered:		
0.5-4.5V dc	+24V dc nom. + 9-28V.	5kΩ min.
0.5-9.5V dc	+24V dc nom. + 13-28V.	5kΩ min.
4-20mA	+24V dc nom. + 13-28V.	300R Max.
Supply Current	10mA typical, 20mA max. plus O/P current	

### CONNECTOR/CABLE OPTIONS

Connector - Hirschmann ELWIK 4102 Axial, IP67  
 Connector - Hirschmann ELWIK 4102 Radial, IP67  
 Cable with Pg 9 gland Axial, IP67  
 Cable with boot. Radial, IP67  
 Cable length >50 cm – please specify length in cm

Output Characteristic - Standard

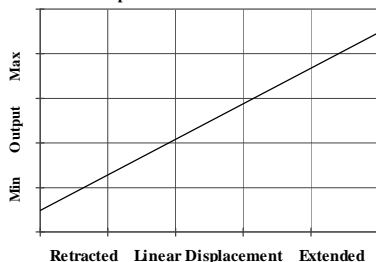

Output Characteristic - Reverse option

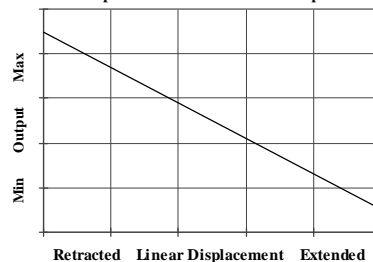

For further information please contact:

[www.positek.com](http://www.positek.com) [sales@positek.com](mailto:sales@positek.com)

Tel: +44(0)1242 820027 fax: +44(0)1242 820615

Positek Ltd, Andoversford Industrial Estate, Cheltenham GL54 4LB U.K.



# LIPS® SERIES P112 Gauge Head Position Sensor

a	b	c	d
P112 . Displacement Output Connections Z-code			

a Displacement (mm)		Value
Displacement in mm	e.g. 0 - 34 mm	34
b Output		
Supply V dc V <sub>s</sub> (tolerance)	Output	Code
+5V (4.5 - 5.5V)	0.5 - 4.5V (ratiometric with supply)	A
+24V nom. (13 - 28V)	0.5 - 9.5V	C
+24V nom. (9 - 28V)	0.5 - 4.5V	G
+24V nom. (13 - 28V)	4 - 20mA 3 wire Source	H
c Connections Cable* or Connector		Code
Cable Boot - Radial	IP67	Ixx
Connector - Axial	IP67 M12 IEC 60947-5-2	J
Connector - Radial	IP67 M12 IEC 60947-5-2	K
Cable Gland - Axial	IP67 Pg9	Lxx
*Supplied with 50 cm as standard, specify required cable length specified in cm. e.g. L2000 specifies cable gland with 20 metres of cable. Nb: restricted cable pull strength.		
d Z-code		Code
≤ ± 0.1% @20°C Independent Linearity displacement between 10mm & 50mm only!		Z650
Connector with cable option 'J' or 'K' with length required in cm i.e. J100 specifies connector with 100cm of cable.		Z999

# Installation Information

## LIPS<sup>®</sup> P112 GAUGE HEAD POSITION SENSOR

Output Option	Output Description:	Supply Voltage: V <sub>s</sub> (tolerance)	Load resistance: (include leads for 4 to 20mA O/Ps)
A	0.5 - 4.5V (ratiometric with supply)	+5V (4.5 - 5.5V)	≥ 5kΩ
C	0.5 - 9.5V	+24V nom. (13 - 28V)	≥ 5kΩ
G	0.5 - 4.5V	+24V nom. (9 - 28V)	≥ 5kΩ
H	4 -20mA	+24V nom. (13 - 28V)	300R MAX

Not all output options available - see product datasheet for full options list

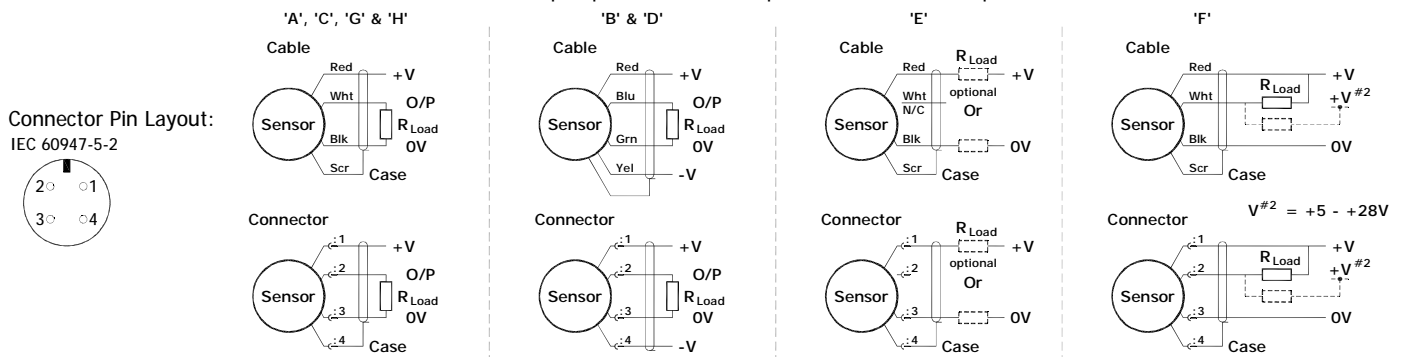

**Mechanical Mounting:** Via 1/2"x20 UNF mounting thread, adjust sensor position and lock in place using lock nuts provided. Maximum tightening torque: 10Nm.

**Output Characteristic:** Plunger is extended 3.3 mm from end of body at start of normal travel. The output increases as the plunger extends from the sensor body, the calibrated stroke is between 5 mm and 50 mm.

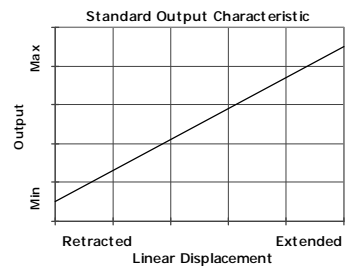

**Warning -** The M12 IEC 60947 connector may be rotated for purposes of convenient orientation of the connector and cable, however rotating the connector more than one complete revolution is not recommended.

**Repeated rotation of the connector will damage the internal wiring!**

**Incorrect Connection Protection levels:-**

- A **Not protected** – the sensor is **not** protected against either reverse polarity or over-voltage. The risk of damage should be minimal where the supply current is limited to less than 50mA.
- C & G Supply leads diode protected. Output must not be taken outside 0 to 12V.
- H Supply and output lead diode protected. Do take output negative of 0 volts.