



# Zettlex IncOder™ Product Guide

## Mini Ultra Range 37-58mm

### High Accuracy

### Inductive Angle Encoders

MINI Revision 4.11.7 June 2020

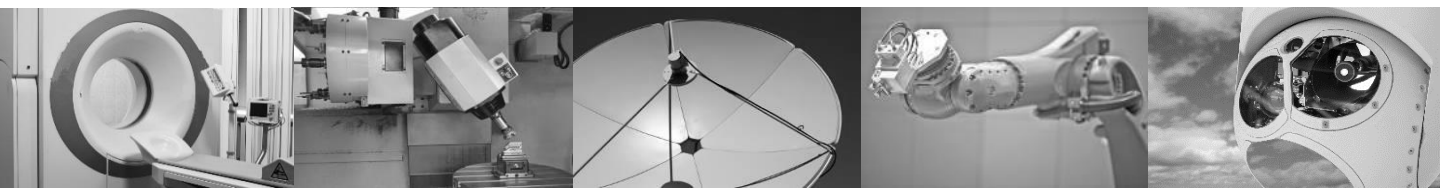

- No contacts
- No bearings
- No couplings
- No maintenance
- Absolute
- Compact
- Easy installation
- Accurate
- Robust
- Integral electronics
- >500 Million product options
- Economical
- Global support



.....they tick all the boxes.



<b>1. Introduction</b>	<b>4</b>
<b>2. Product Options</b>	<b>6</b>
<b>3. Manufacturing &amp; Quality</b>	<b>7</b>
<b>4. Technical Data</b>	<b>8</b>
4.1 Ultra High Accuracy 58mm IncOder Servo Clamp Stator & Plain Rotor - Product Option INC-6H	8
4.2 Ultra High Accuracy 58mm IncOder Servo Clamp Stator & Shaft Clamp Rotor - Product Option INC-11H	10
4.3 58mm IncOder Radial and Axial Connections - Product Options AC1-2, RC1-2	12
4.4 58mm IncOder Integral Axial Cable - Product Options AFLx & VFLx	14
4.5 Ultra High Accuracy 37mm IncOder Servo Clamp Stator & Set Screw Rotor - Product Option INC-4H	17
4.6 Ultra High Accuracy 37mm IncOder Screw Mount Stator & Plain Rotor - Product Option INC-8H	19
4.7 37mm IncOder Electronics Module – Product Options RC371-RC374	21
4.8 Extended Product Range	22
4.9 Measurement & Electrical Data (58mm IncOder)	24
4.10 Environmental & Further Data (58mm IncOder)	25
4.11 Measurement, Electrical & Environmental Data (37mm IncOder)	26
<b>5. Customised Products</b>	<b>27</b>
<b>6. Communication Interfaces</b>	<b>28</b>
6.1 Output Resolution	28
6.2 Multi-Turn or Single Turn	28
6.3 Zero Point, Zero Set & Zero Reset for Digital Outputs (58mm IncOder)	28
6.4 Synchronous Serial Interface (SSI) - Product Options SSI1-SSI9	29
6.5 Asynchronous Serial Interface - Product Options ASI1-2	32
6.6 Serial Peripheral Interface - Product Option SPI1	33
6.7 A/B/Z Pulse Interface – Product Options ABZ1 to ABZ6 (58mm IncOder)	35
6.8 BiSS-C Interface – Product Option BIS3	36
<b>7. Connector Diagrams</b>	<b>37</b>
7.1 58mm IncOder Connector Pin Assignments	37
7.2 37mm IncOder Wire Diagram & Zero Setting	37
<b>8. Product Ordering</b>	<b>38</b>
8.1 Product Ordering 58mm IncOder	38
8.2 Product Ordering 37mm IncOder	39
8.3 Product Ordering - General	40
8.4 Product Ordering - Extended Range	40
<b>9. Accessories</b>	<b>41</b>
<b>10. Frequently Asked Questions</b>	<b>44</b>



# 1. Introduction

Zettlex IncOders are non-contact devices for precise angle measurement. They use an inductive technique, similar to that used by electrical transformers. IncOders may be considered as an inductive encoder.

Ultra High Accuracy IncOders are calibrated for improved accuracy and an accuracy certificate is provided with each unit.

IncOders are well suited to harsh environments - where potentiometers, optical or capacitive devices might be unreliable.

IncOders have two main parts each shaped like a flat ring: a Stator and a Rotor. The Stator is powered and measures the angular position of the passive Rotor. 58mm IncOders house all associated electronics within the stator whereas for 37mm IncOders, these electronics are distributed across the stator and a separate remote electronics board found in the cable assembly.

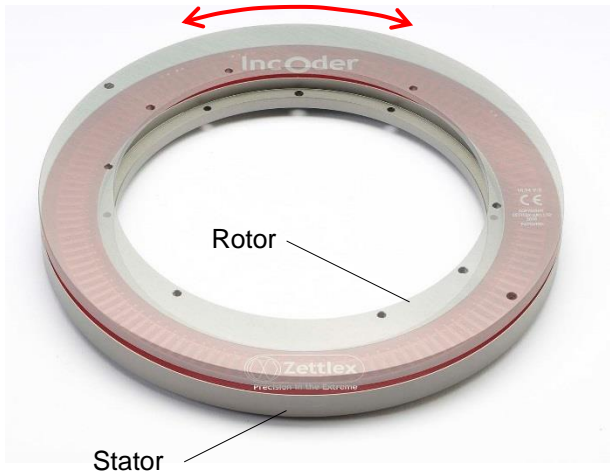

A big bore and low axial height allows easy integration with through-shafts, slip-rings, direct drive motors, optical-fibres, pipes or cables.

IncOder technology is proven technology – tried and tested in tough conditions on land, sea and in the air.

IncOders require no service or maintenance and so they are 'fit and forget' devices.

**They are designed and built so they won't let you down when the going gets tough.**

IncOders make it easy to achieve high precision, high reliability angle measurement.



There is no need to consider bearing alignment, seals or wearing parts.

Whereas optical or capacitive sensors can be unreliable in harsh conditions – notably with condensation or dust - IncOders are generally unaffected by foreign matter and IP68 rated versions are available.

Unlike capacitive devices, there is no need to earth the Rotor or Stator.

Robust, aluminium alloy housings with SurTec650 surface finish and monolithic constructions are used throughout.



IncOders contain all the electronics to receive power and output a signal. The output signal shows the position of the Rotor relative to the Stator.

Devices with absolute digital outputs, such as SSI, SPI etc., are truly absolute which means that they need no motion at power up to determine position. Some devices (58mm) offer the option of incremental (A/B pulse) output.

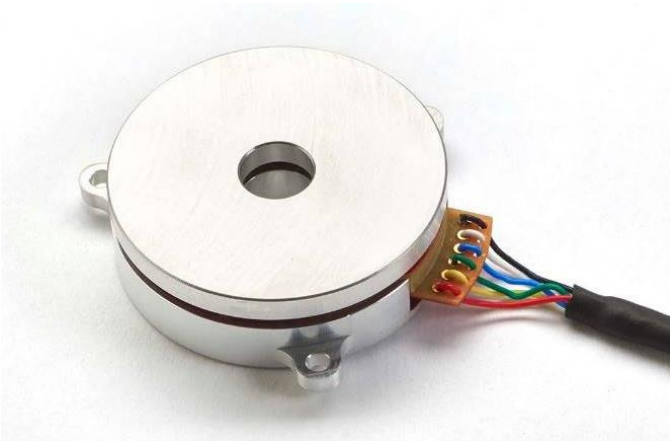

Compliant or special couplings are not required, so the Rotor & Stator can simply be fixed directly to the host product.

Precise mechanical mounting is not necessary to achieve high measurement performance and there are no bearings.

The measurement performance stated in this Product Guide is guaranteed provided that the IncOder is installed as per its installation tolerances.

IncOders have a solid track record in demanding applications such as industrial machinery, security and defence equipment, naval and marine equipment. IncOders are designed and built in ISO-9001 accredited facilities in the United Kingdom; contain no ITAR restricted components and do not require an export licence unless they are >1000mm diameter.

Applications include :-

- Rotary joints & gimbals
- Actuator servos & motor encoders
- Electro-optical & infra-red camera systems
- Heliostats & solar equipment
- Robotic arms & CNC machine tools
- Antenna pointing devices & telescopes
- Packaging & laboratory automation
- Medical scanners & surgical equipment
- Cranes & telescopic manipulators
- Test & calibration equipment.



Ultra High Accuracy Mini units are available with up to 75 arc-seconds accuracy depending on size (see Section 4.9/4.11). Each unit is calibrated for improved accuracy and an accuracy certificate is supplied with each unit. Each IncOder contains one Stator and one Rotor. Each IncOder contains one Stator and one Rotor, and supplied as a matched pair. The range of options are:-

**Mechanical Format** : mechanical formats include screw mount and servo clamp stators as well as plain, shaft clamp and set-screw rotors – see Section 4.

**IncOder Size** : stated as outer diameter: 37 and 58mm in the Mini IncOder range – see Section 4.

**Resolution Options** : up to 20 bits for 58mm units; up to 17 bits for 37mm units - see Section 6.1.

**Communication Interface Options:**

Synchronous Serial Interface – see Section 6.4 for various formats (Product Options SSI1-9)

Asynchronous Serial Interface – see Section 6.5 (Product Option ASI1 & ASI2)

Serial Peripheral Interface – see Section 6.6 (Product Option SPI1)

A/B/Z pulses – see Section 6.7 (Product Option ABZ1-6)

BISS-C – see Section 6.8 (Product Options BIS3)

**Connection Options** : radial and axial connections as well as integral cables – see Section 4.3, 4.4, 4.7.

**Voltage Options** : 5, 12 or 24VDC.

**Extended Range Options** : these options are only intended for ultra high-reliability applications which may require extended thermal stress screening, bake-out, high shock/vibration constructions, leaded solder, low or high operating temperatures – see Section 4.8.



IncOders are designed, made, tested and shipped by our facility in Cambridge, UK. Support is provided by the same site or through our global network of partners.



IncOder manufacturing processes are well established, having been perfected over years and the production of thousands of products. Every IncOder is serial numbered and tested according to a rigorous acceptance test procedure before dispatch. Detailed test records for every IncOder are stored by Celera Motion.



Certificates of conformity are available as well as a RoHS compliance certificate and a REACH statement. IncOders are not ITAR restricted and use no ITAR components. A UK government export license is typically not required for the devices specified in this Product Guide.

All design, manufacturing and commercial processes operate under a comprehensive ISO-9001:2015 quality management system, developed by Zettlex engineers. The quality management system is subject to regular internal and external audit – including an annual audit by a UKAS accredited, independent authority. Zettlex is also certified for the design and manufacture of intrinsically safe (ATEX) sensors under BS EN 13980. Electronics manufacturing is to IPC Class III standards.

A copy of our ISO-9001 and ATEX certificate is available on [www.celeramotion.com](http://www.celeramotion.com).



# 4.1 58mm IncOder Servo Clamp Stator & Plain Rotor – Product Option INC-6H

**NOTES**

1. **3D CAD MODEL FILES AVAILABLE ON [WWW.CELERAMOTION.COM](http://WWW.CELERAMOTION.COM)**
2. ALL DIMS IN mm – DO NOT SCALE
3. 3<sup>RD</sup> ANGLE PROJECTION
4. AL. ALLOY HOUSINGS SURTEC650 SURFACE PROTECTION 0.11-0.50g/m<sup>2</sup>
5. UNLESS STATED, TOLERANCES:-  
 0 DECIMAL PLACES = ±0.5  
 1 DECIMAL PLACES = ±0.2  
 2 DECIMAL PLACES = ±0.1

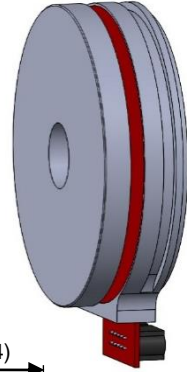

PLAN VIEW SHOWING AC2 CONNECTION

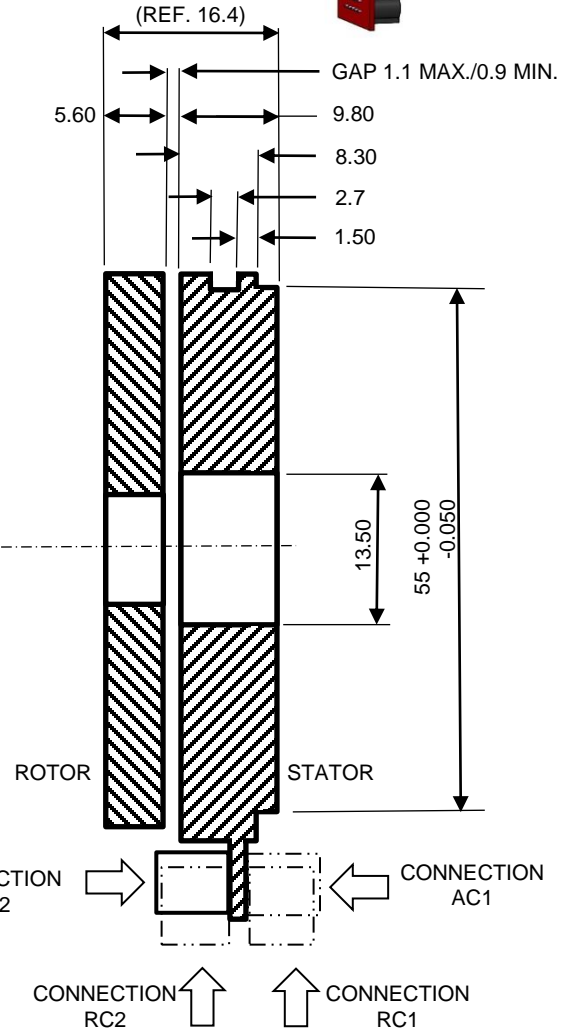
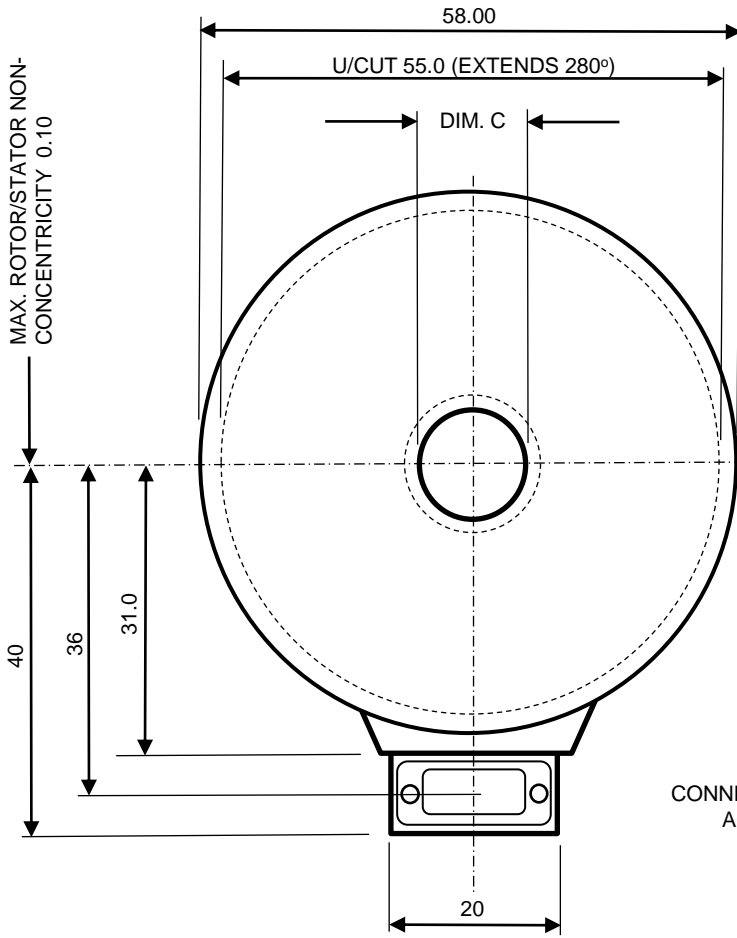

SCRAP VIEW SHOWING VFLx CONNECTION

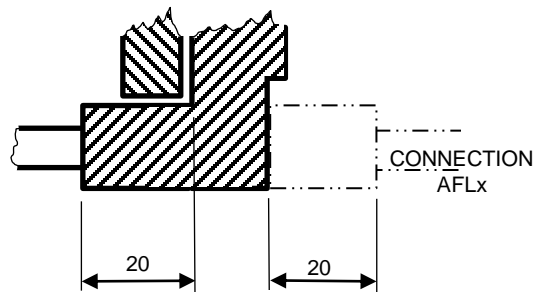
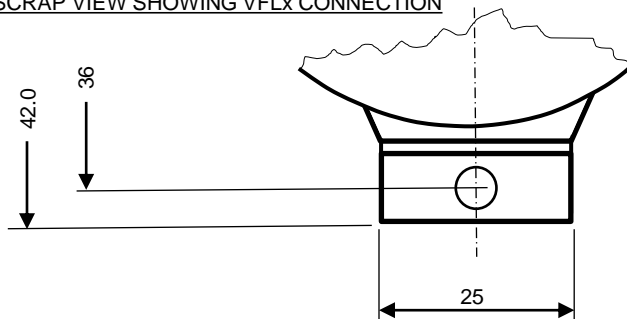

OPTIONS FOR DIM C = 6.00, 10.00, 12.00 & 12.70 ALL WITH H7 TOLERANCE.

OPTIONS FOR CONNECTOR = AC1, AC2, RC1, RC2, AFL1 TO 5, VFL1 TO 5 - SEE SECTION 8 ON HOW TO SELECT BY PART NUMBER.



# 4.1 58mm IncOder Servo Clamp Stator & Plain Rotor – Product Option INC-6H

58mm IncOders can be installed in various ways and the following sketches shows an example. Provided the axial gap and concentricity tolerances are maintained, then the stated measurement performance will be met.

OPTIONAL SERVO CLAMPS x2 MIN.  
(PREFERABLY x3 - SEE ACCESSORIES  
SECTION 9.3)

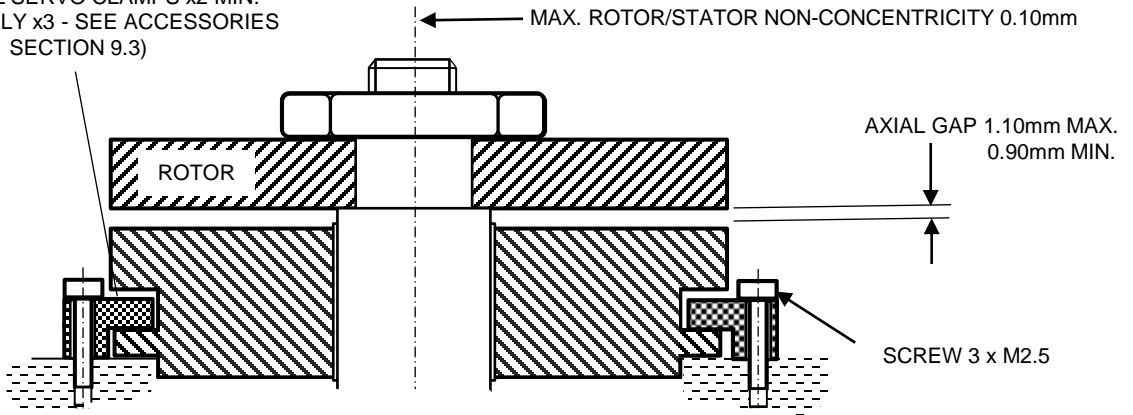

SCREW STATOR & PLAIN  
ROTOR SHOWN

# 4.2 58mm IncOder Servo Clamp Stator & Shaft Clamp Rotor – Product Option INC-11H

## NOTES

1. **3D CAD MODEL FILES AVAILABLE ON [WWW.CELERAMOTION.COM](http://WWW.CELERAMOTION.COM)**
2. ALL DIMS IN mm – DO NOT SCALE
3. 3<sup>RD</sup> ANGLE PROJECTION
4. AL. ALLOY HOUSINGS SURTEC650 SURFACE PROTECTION 0.11-0.50g/m<sup>2</sup>
5. UNLESS STATED, TOLERANCES:-  
 0 DECIMAL PLACES =  $\pm 0.5$   
 1 DECIMAL PLACES =  $\pm 0.2$   
 2 DECIMAL PLACES =  $\pm 0.1$

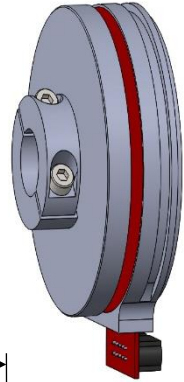

PLAN VIEW SHOWING AC2 CONNECTION

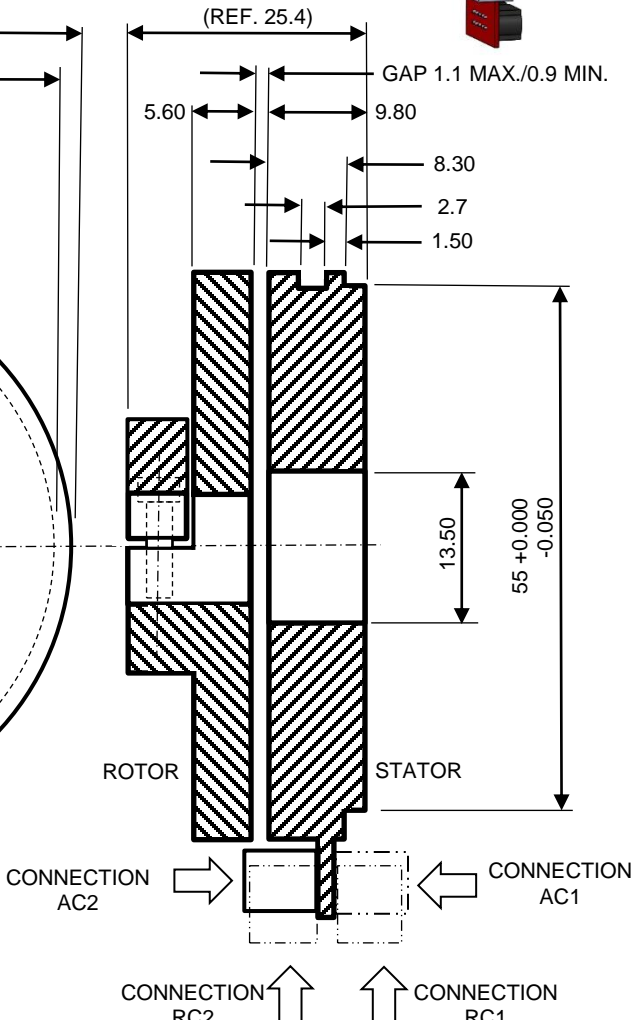
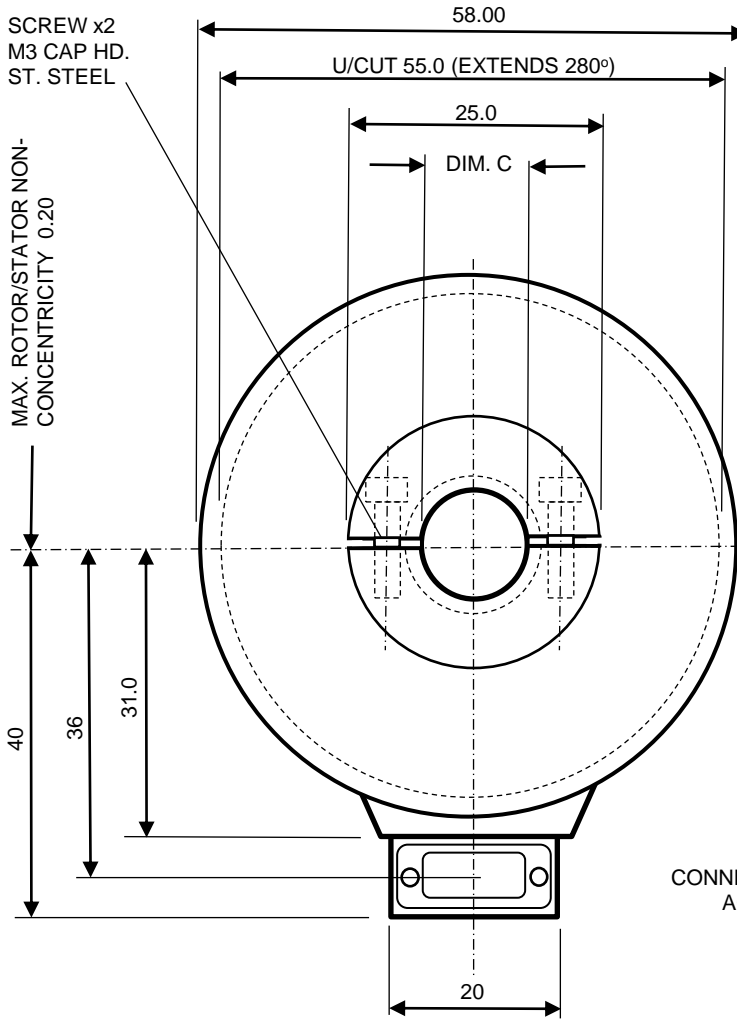

SCRAP VIEW SHOWING VFLx CONNECTION

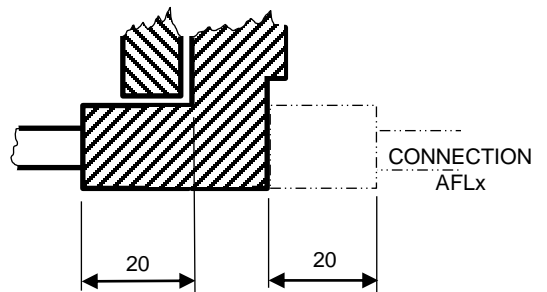
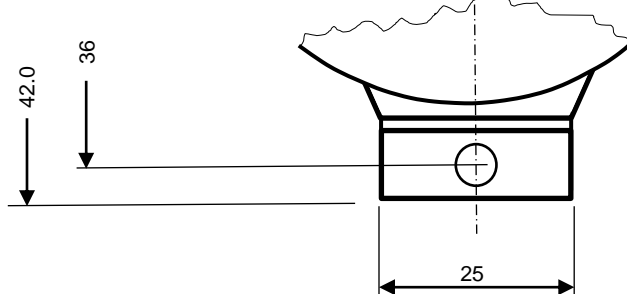

OPTIONS FOR DIM C = 6.00, 10.00, 12.00 & 12.70 ALL WITH H7 TOLERANCE.

OPTIONS FOR CONNECTOR = AC1, AC2, RC1, RC2, AFL1 TO 5, VFL1 TO 5 - SEE SECTION 8 ON HOW TO SELECT BY PART NUMBER.

# 4.2 58mm IncOder Servo Clamp Stator & Shaft Clamp Rotor – Product Option INC-11H

58mm IncOders can be installed in various ways and the following sketches shows an example. Provided the axial gap and concentricity tolerances are maintained, then the stated measurement performance will be met.

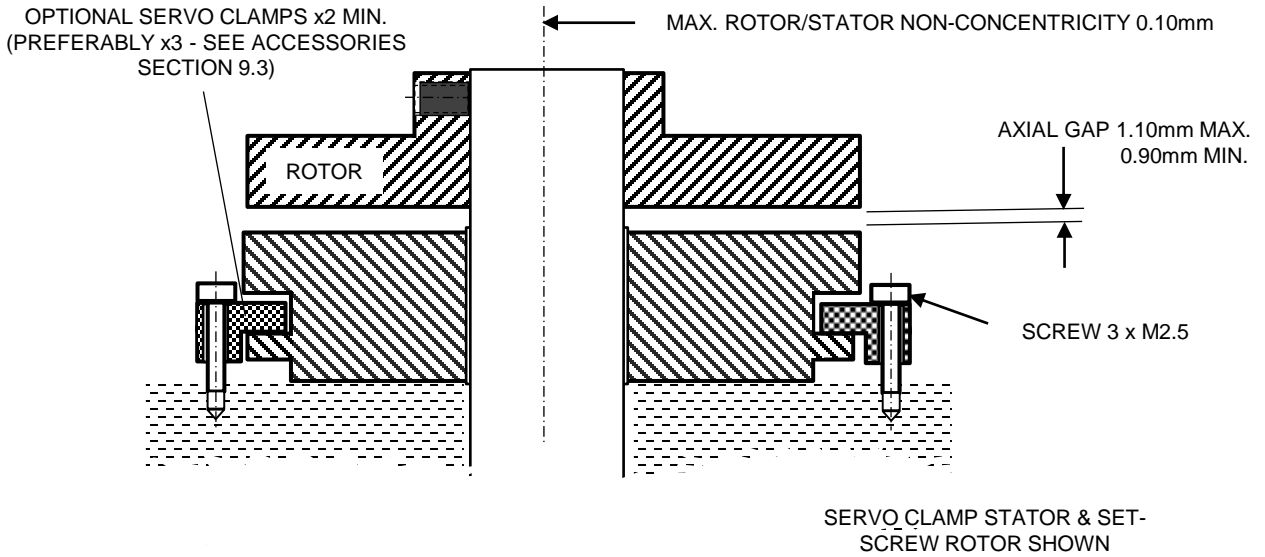

## 4.3 58mm IncOder Radial and Axial Connections – Product Options AC1-2, RC1-2

AC1 is the most common IncOder connector option. This option features a Harwin Datamate connector oriented axially on the obverse side of the sensor stator. Compatible cable options can be found in Section 9.

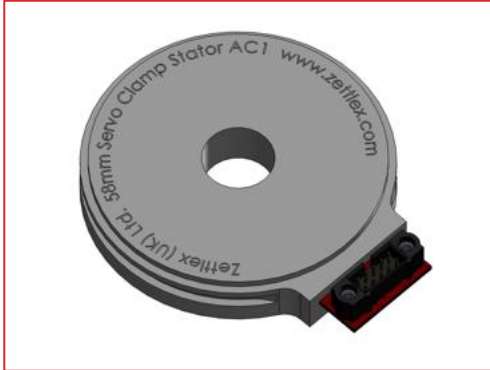

**AC1** – Axial Connector, direction 1

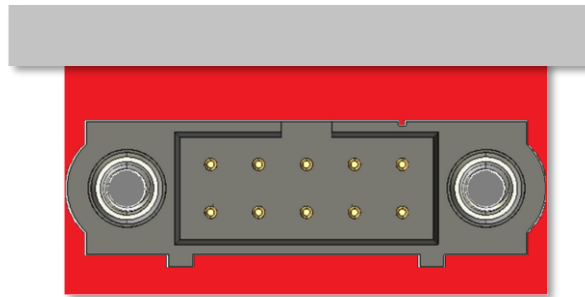

**Notes:**

- Pinouts detailed in Section 7.1.
- See Mounting Formats for dimensions on AC1 connector types.
- Connector: Harwin Data Mate Vertical Plug 10 Way with 2 Jack Screws - Type M80-5001042 or equivalent.
- Required Mating Connector: Harwin Data Mate Vertical Socket Type M80-4611042 or equivalent.
- See accessories section for compatible cable options.
- Material: Polyphenylene sulfide (PPS) with Stainless Steel Screw Fixings and Gold & Tin Electrical Connections.

## 4.3 58mm IncOder Radial and Axial Connections – Product Options AC1-2, RC1-2

For 58mm Shaft IncOders, there are 4 connector options, as pictured below. See Section 4.4 for integral connector options.



**AC1** – Axial Connector, direction 1.

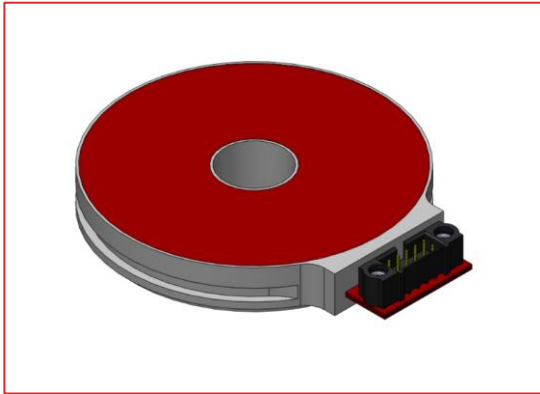

**AC2** – Axial Connector, direction 2.

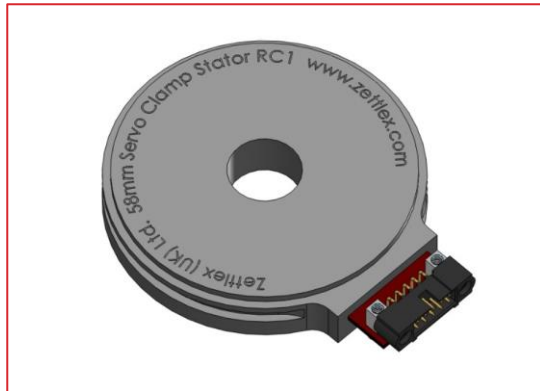

**RC1** – Radial Connector, direction 1.

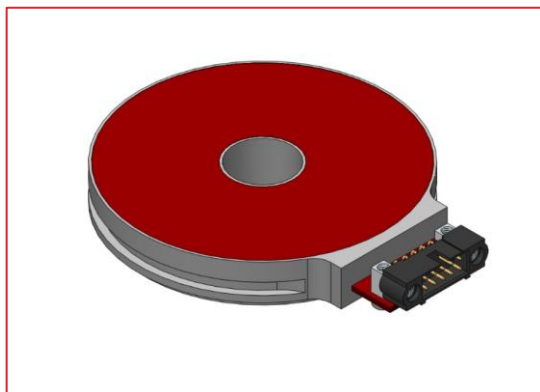

**RC2** – Radial Connector, direction 2.

## 4.4.1 Integral Cable Product Options AFL1-52 & VFL1-52

Integral Axial Cables are for wet and/or severe shock/vibration environments. The connector is replaced by an integral cable and a block which covers the cable to IncOder joint. Each option features 24 AWG multi-strand copper wire twisted pairs and rated to IP67 for 1 hour and 1m depth. Sealed variants of each cable additional protection for immersion at depth.

### A/VFL1 – Integral Axial Cable. A/VFL2 – Integral Axial Cable, Sealed.



- Length: 2m
- Shield: Overall foil shield with tinned copper drain wire
- Insulation: Semi-rigid PVC
- Outer Jacket: Semi-rigid PVC
- Bend Radius = 20mm (1-off fixed) & 76mm (flexing)
- Outer Diameter: 7.3mm
- Operating temp.: -30 to 80°C
- UL AWM Style 2464

### A/VFL3 – Integral Axial, High Flex Cable. A/VFL32 – Integral Axial, High Flex Cable, Sealed.



*Suitable for repeat bending (>5M cycles)*

- IGUS CF11.02.05.02 cable
- Length: 2m
- Shield: Extremely bending-stable tinned copper wire braid
- Outer Jacket: Extremely bending-stable TPE mixture
- Bend Radius = 45mm (fixed) & 61mm (flexing)
- Outer Diameter: 9.0mm
- Operating temp.: -35 to +85°C (flexing) or -40 to +85°C (fixed)
- PVC & halogen free
- Hydrolysis, oil, UV & microbe resistant

### A/VFL5 Integral Axial, PTFE/MIL-Spec Cable. A/VFL52 Integral Axial, PTFE/MIL-Spec Cable, Sealed.



- Length: 1.1m
- Insulation: BS 3G 210 Type A PTFE coated wire
- Shield: Tin plated copper braid
- Outer Jacket: MIL-1-23053/12 Class 3 AMS3584 PTFE sleeve
- Bend Radius = 12mm (fixed) & 76mm (flexing)
- Operating temp.: -60 to +105°C
- Non-flammable cable, resistant to oils, lubricants, fuels

NOTE: If being used in high vibration/shock, cables need to be provided with suitable strain relief and support. Length specified is minimum supplied cable length -50mm or -5%, whichever is greater. See Sections 4.4.4 for further details on cable length.

# 4.4 58mm IncOder Integral Axial Cable - Product Options AFL1-52 & VFL1-52

## 4.4.2 AFL & VFL Dimensions :-

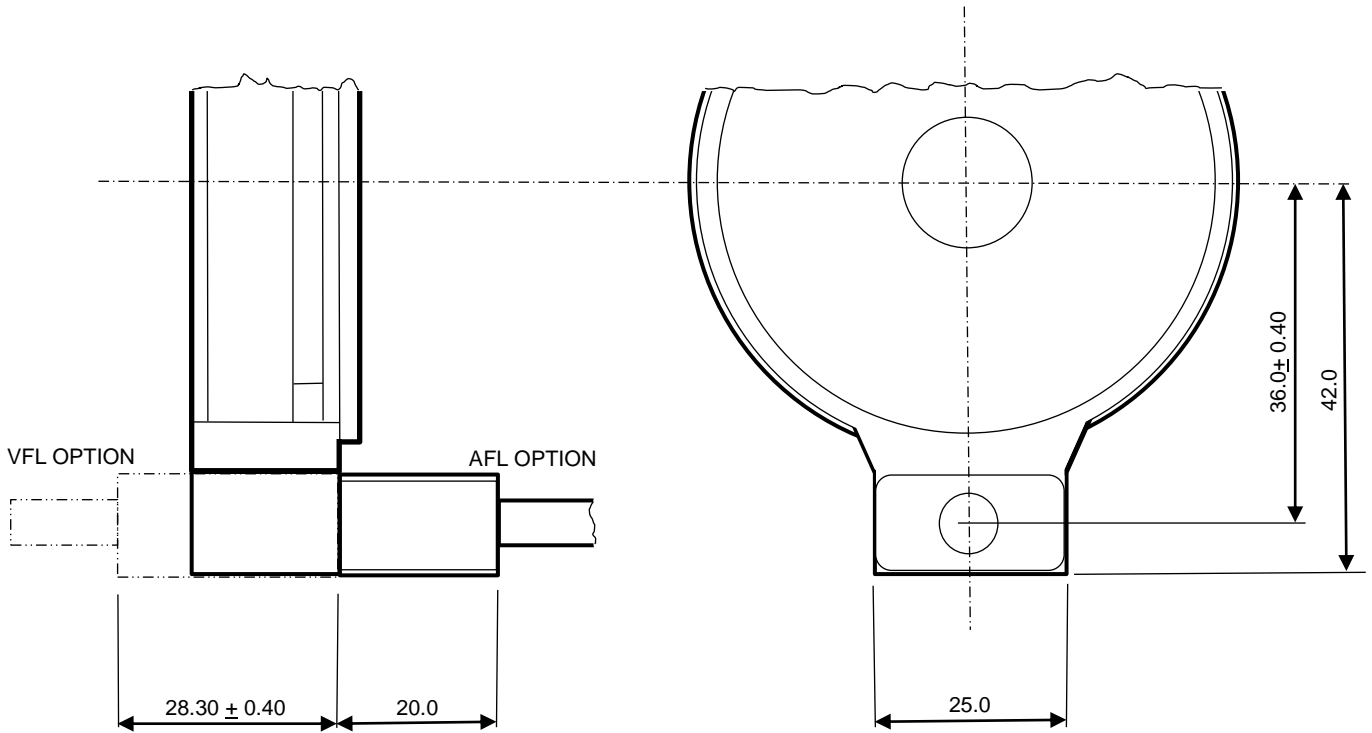

- Notes
- 58mm stator shown only.
  - Drawing shown in 3rd angle projection. Do not scale from drawing
  - All dims in mm. Gen. tol. =  $\pm 1$ mm unless stated - all other dims as per relevant mechanical drawings.

## 4.4.3 FL Wiring Assignment

**Table A - Connections for AFL1, VFL1, AFL2, VFL2, AFL5, VFL5, AFL52, VFL52**

Pair No.	Colour	Connector Pin (For Info. Only)	Signal (SSI1-9 & SPI & BISS-C)	Signal (ASI1 & ASI2)	Signal (A/B pulses & Z Ref.)
1	Black	7	Data B	Data B	A complement
1	Green	5	Data A	Data A	A
2	Black	6	Clk B	Not used - do not connect	B complement
2	Blue	8	Clk A	Not used - do not connect	B
3	Black	9	0V	0V	0V
3	Red	10	V <sub>supply</sub>	V <sub>supply</sub>	V <sub>supply</sub>
4	Black	1	Zero Set	Zero Set	Z Ref Set
4	Yellow	2	Zero Reset	Zero Reset	Z Ref. Reset
5	Black	3	Not used - do not connect	Not used - do not connect	Z
5	White	4	Not used - do not connect	Not used - do not connect	Z complement

**Table B - Wiring connections for AFL3, AFL32, VFL3 & VFL32**

Pair No.	Colour	Connector Pin (For Info. Only)	Signal (SSI1-9 & SPI & BISS-C)	Signal (ASI1 & ASI2)	Signal (A/B pulses & Z Ref.)
1	Grey	7	Data B	Data B	A complement
1	Pink	5	Data A	Data A	A
2	Yellow	6	Clk B	Not used - do not connect	B complement
2	Green	8	Clk A	Not used - do not connect	B
3	Blue	9	0V	0V	0V
3	Red	10	V <sub>supply</sub>	V <sub>supply</sub>	V <sub>supply</sub>
4	Violet	1	Zero Set	Zero Set	Z Ref Set
4	Black	2	Zero Reset	Zero Reset	Z Ref. Reset
5	Brown	3	Not used - do not connect	Not used - do not connect	Z
5	White	4	Not used - do not connect	Not used - do not connect	Z complement

## 4.4.4 Cable Lengths for FL Product Options

Standard length for xFL1, xFL2, xFL3 & xFL32 cables is 2m. If a different cable length is required, simply change the part number from, for example, AFL1 to AFL1.5.0 for a 5.0m cable or from AFL32 to a AFL32.0.9 for a 0.9m cable. Standard (and maximum possible) length for xFL5 & xFL52 is 1.1m. For shorter cables there is no price difference. There may be a price variation for integral cables longer than standard – contact Celera Motion or your local rep. Tolerance on minimum cable length is -50mm or -5%, whichever is greater.

## 4.4.5 Connectors for FL Product Options

Fitting special connectors such as D-38999 military type or hermetically sealed connectors is something that we are frequently asked to do. Please contact us or your local representative if this is a requirement, stating cable type (preferably choose from cables described in Section 4.4), cable length & connector type.





# 4.5 37mm IncOder Servo Clamp Stator & Set Screw Rotor – Product Option INC-4H

## NOTES

1. **3D CAD MODEL FILES AVAILABLE ON [WWW.CELERAMOTION.COM](http://WWW.CELERAMOTION.COM)**
2. ALL DIMS IN mm – DO NOT SCALE
3. 3<sup>RD</sup> ANGLE PROJECTION
4. AL. ALLOY HOUSINGS SURTEC650 SURFACE PROTECTION 0.11-0.50g/m<sup>2</sup>
5. UNLESS STATED, TOLERANCES:-  
0 DECIMAL PLACES =  $\pm 0.5$   
1 DECIMAL PLACES =  $\pm 0.2$   
2 DECIMAL PLACES =  $\pm 0.1$

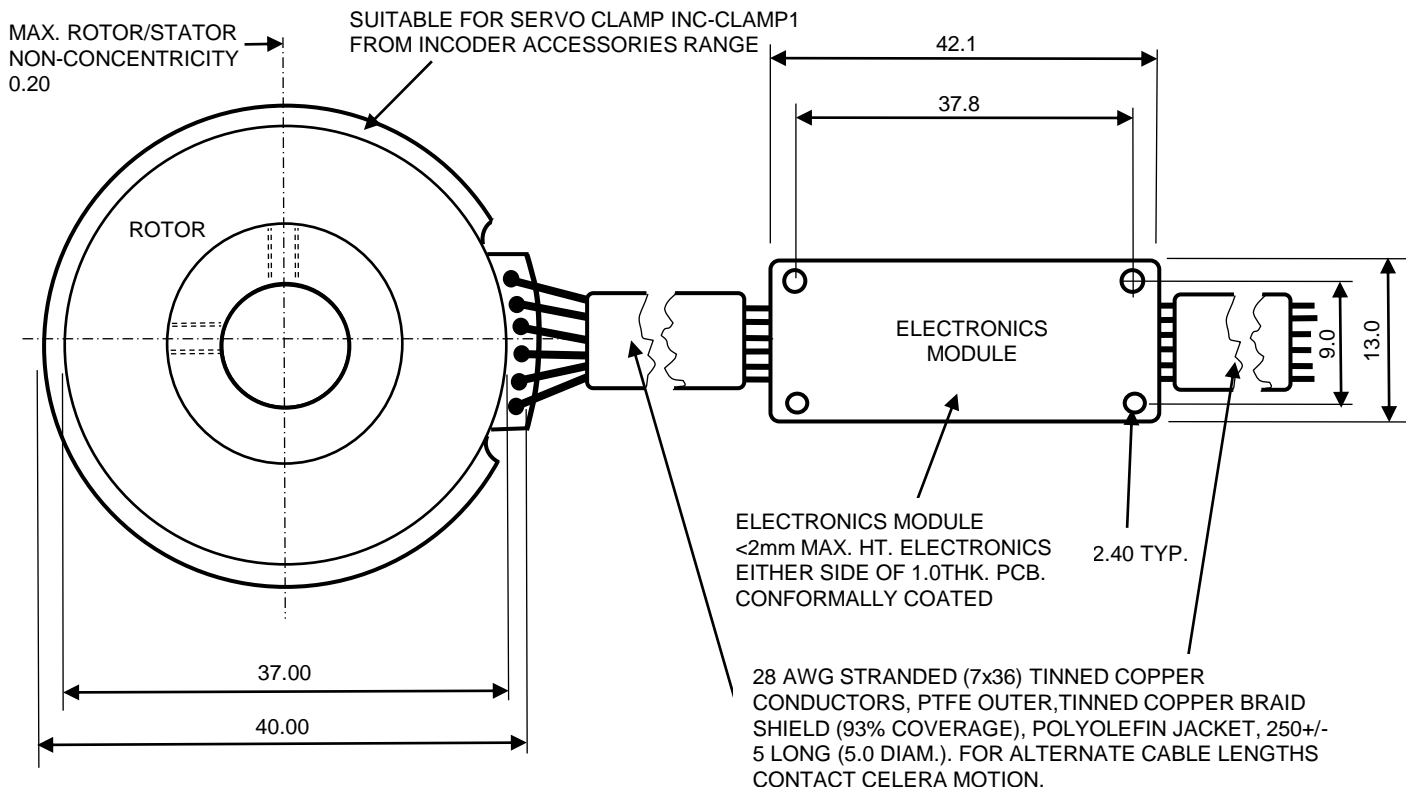
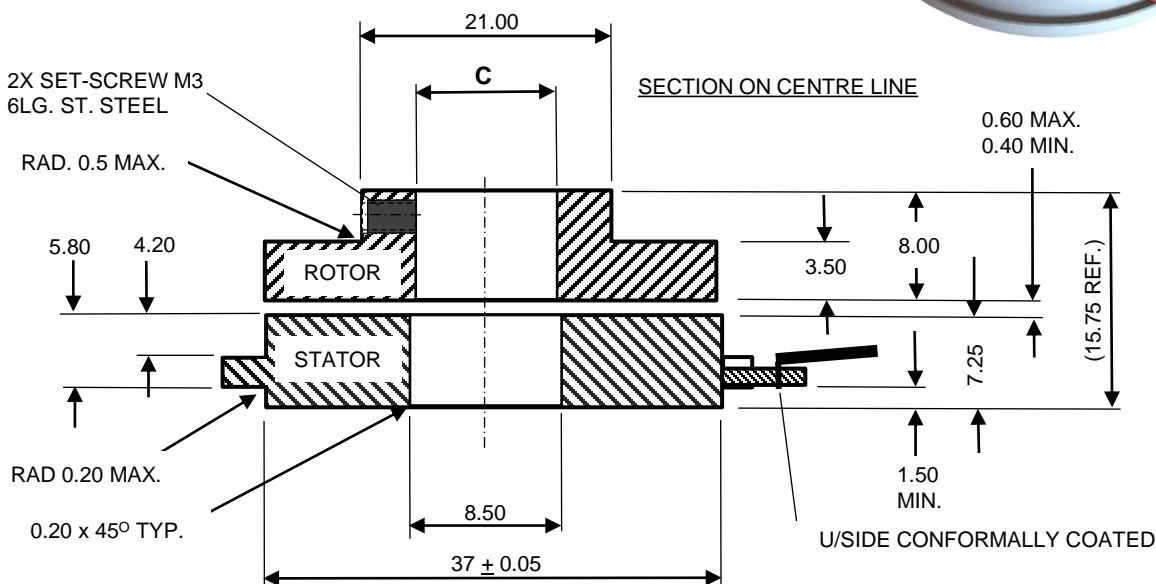
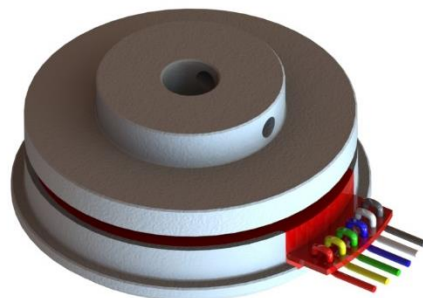

# 4.5 37mm IncOder Servo Clamp Stator & Set Screw Rotor – Product Option INC-4H

37mm IncOders can be installed in various ways. The following sketches show some examples. Provided axial gap and concentricity tolerances are maintained, the stated measurement performance will be met.

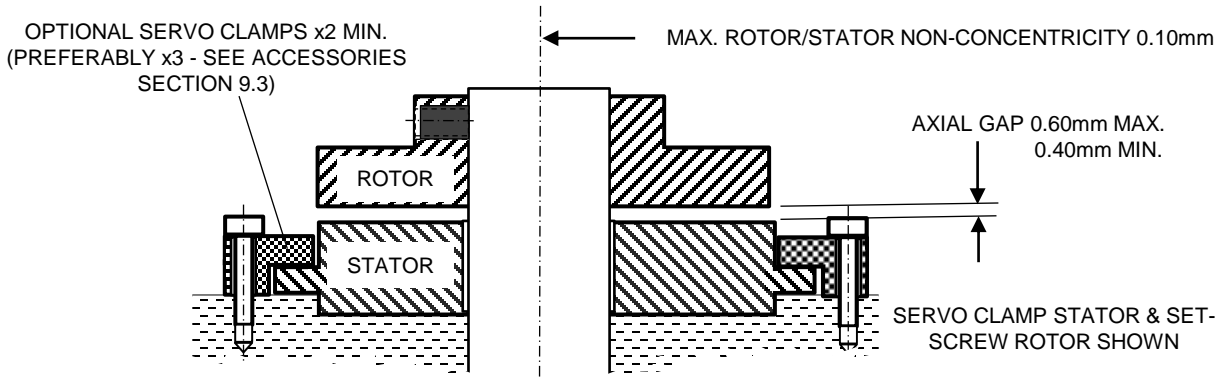

# 4.6 37mm IncOder Screw Mount Stator & Plain Rotor – Product Option INC-8H

## NOTES

1. 3D CAD MODEL FILES AVAILABLE ON [WWW.CELERAMOTION.COM](http://WWW.CELERAMOTION.COM)
2. ALL DIMS IN mm – DO NOT SCALE
3. 3<sup>RD</sup> ANGLE PROJECTION
4. AL. ALLOY HOUSINGS SURTEC650 SURFACE PROTECTION 0.11-0.50g/m<sup>2</sup>
5. UNLESS STATED, TOLERANCES:-  
 0 DECIMAL PLACES = ±0.5  
 1 DECIMAL PLACES = ±0.2  
 2 DECIMAL PLACES = ±0.1

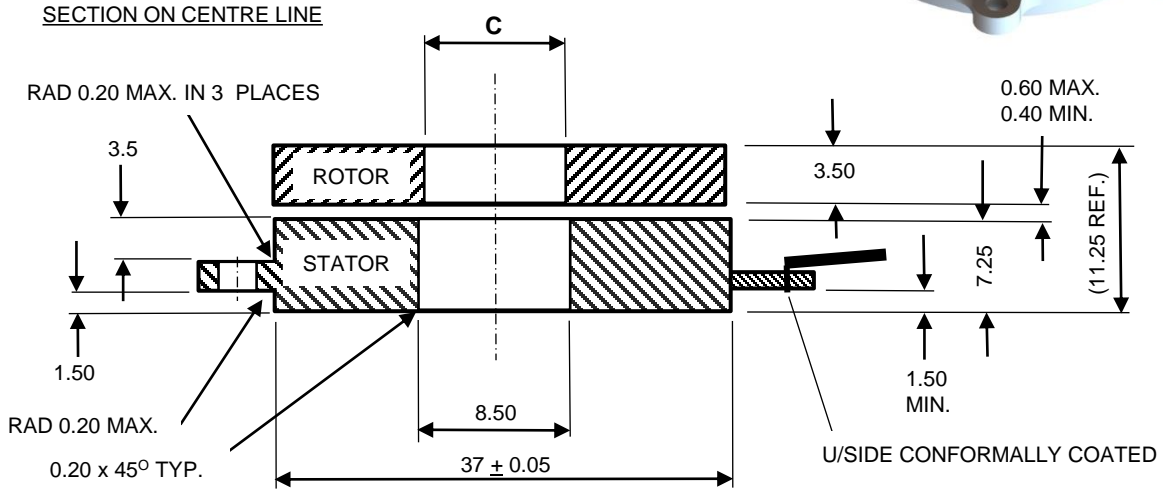
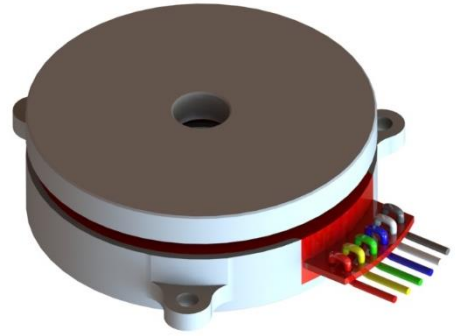

3 HOLES 2.40 THRO'  $\varnothing 0.10$   
ON 42.00 P.C.D.

MAX. ROTOR/STATOR  
NON-CONCENTRICITY 0.20

FULL RAD 2.5 TYP.

RAD 3 TYP.

ROTOR

37.00

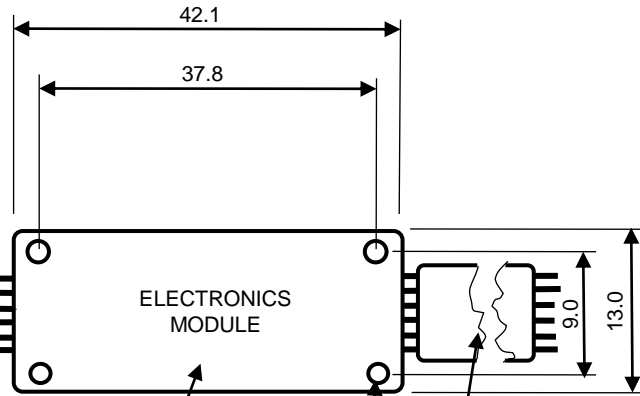

ELECTRONICS MODULE  
<2mm MAX. HT. ELECTRONICS  
EITHER SIDE OF 1.0THK. PCB.  
CONFORMALLY COATED

2.40 TYP.

28 AWG STRANDED (7x36) TINNED COPPER  
CONDUCTORS, PTFE OUTER, TINNED COPPER BRAID  
SHIELD (93% COVERAGE), POLYOLEFIN JACKET, 250+/-  
5 LONG (5.0 DIAM.). FOR ALTERNATE CABLE LENGTHS  
CONTACT CELERA MOTION.

## 4.6 37mm IncOder Screw Mount Stator & Plain Rotor – Product Option INC-8H

37mm IncOders can be installed in various ways. The following sketches show some examples. Provided axial gap and concentricity tolerances are maintained, the stated measurement performance will be met.

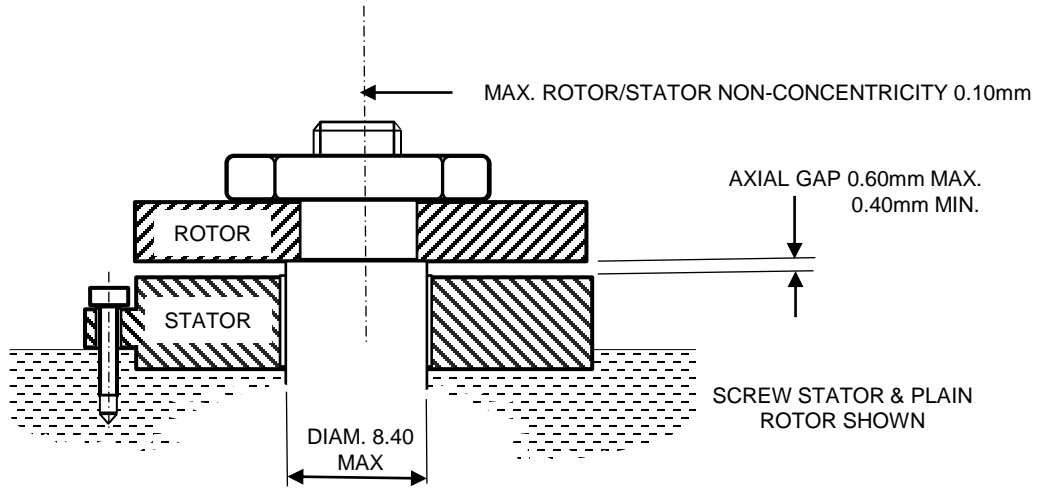

# 4.7 37mm IncOder Electronics Module – Product Options RC371-RC374

For compactness, the 37mm IncOder associated electronics are distributed across the Stator and a remote Electronics Module within an integral cable assembly, rather than a connector. Options RC371, RC372, RC373 and RC374 enable you to select the length of the cable from the E-board module to the user, as well as whether a protective mechanical housing is required.

37mm IncOder Electronics Modules are available with a protective, mechanical housing as shown below (Product Option RC373 with 250+250mm cable lengths or RC374 with 250+2000mm cable lengths). The E-board is mounted into the housing with M2x4 Posi Pan screws and partially sealed with potting. The Housing is aluminium alloy and Surtec protected. Weight of Housing (excluding cables but including Electronics Module) is 25grams. Housing lid is attached with M2x4 Posi CSK screws with Loctite 222 threadlock fastener and is easily removable for access to Zero Set/Reset function (see Section 7.2 for details).

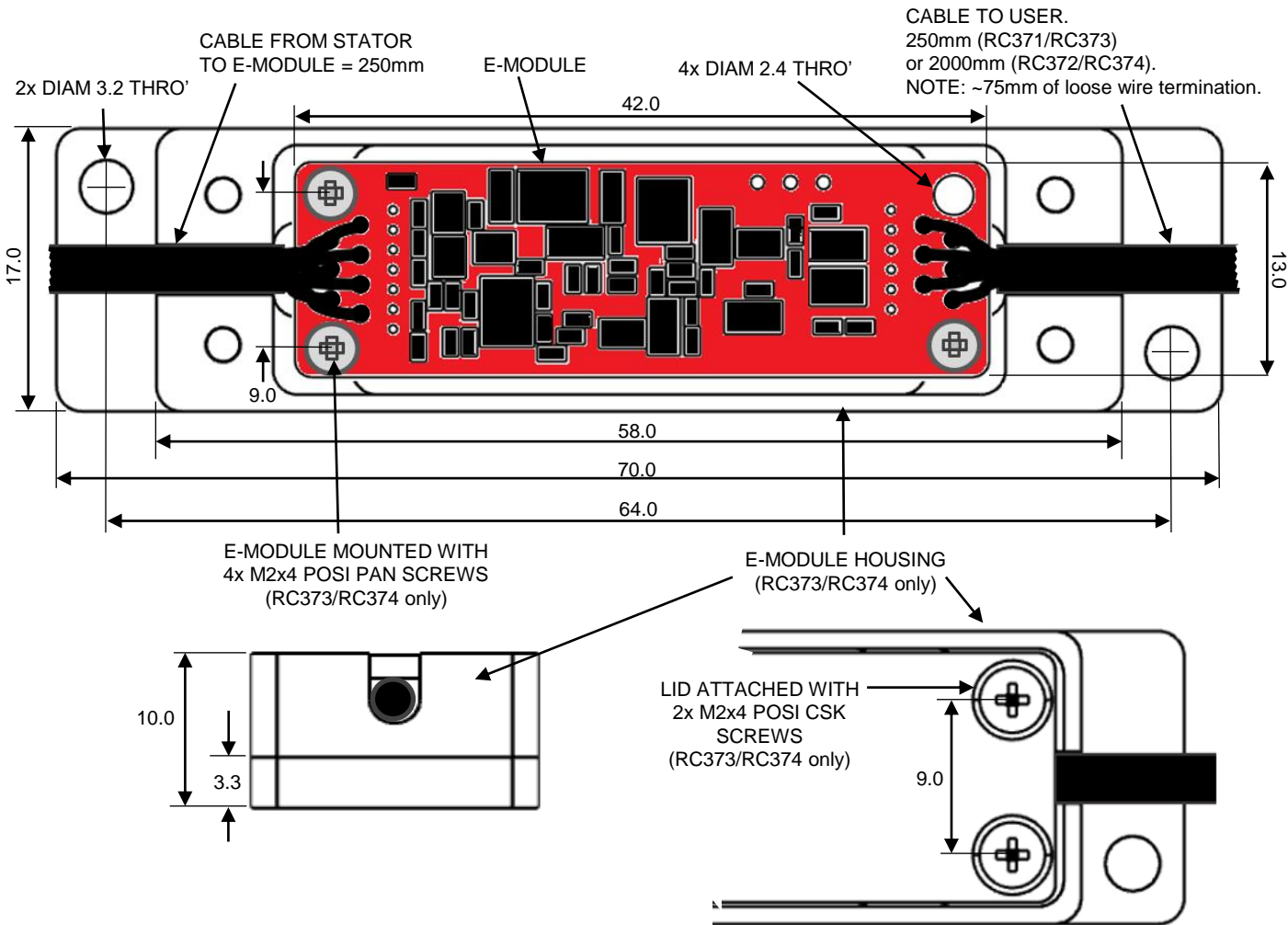

	RC371	RC372	RC373	RC374
Dim. L - Cable to User Length (mm)	250.00	2000.00	250.00	2000.00
E-Module Housing Included?	No	No	Yes	Yes

Extended Product Range Options are not necessary for most applications. In some, such as ultra high-spec applications in defence, aerospace and extreme duty industrial applications, Extended Product Options may be required. Extended Product Options increase product costs & lead-times and should only be specified if necessary.

### **Electronics with Leaded Solder – Extended Product Option ‘P’**

Standard IncOders use RoHS compliant solder for electronic components. In some applications, the use of leaded solder is mandatory. Specify ‘P’ at the end of the standard Product Number.

### **Extended Thermal Stress Screen/Bake-Off – Extended Product Option ‘B’**

Standard IncOders undergo a rigorous final test after assembly. In some applications, extended thermal stress screening (or ‘burn-in’) is required. Similarly, some applications require eradication of any volatile organic compounds. An extended thermal stress screen / bake-out for 24 hours at 70°C prior to final testing may be specified. Specify ‘B’ at the end of the standard Product Number.

### **Very High Shock & Vibration – Extended Product Option ‘G’ (58mm only)**

Standard IncOders are designed for high shock & vibration environments, often found in airborne, marine & military vehicles. In applications with prolonged, very high shock (to 500g for 11ms) and/or very high vibration environments (to 100g for 10-2000Hz) the Very High Shock & Vibration Product Option should be specified. Example applications include (direct mounted) weapons systems, wing mounted aerospace equipment and earth moving vehicles. This option is available in all IncOder sizes, formats and electrical interfaces but, preferably, should be used with integral cables (type AFL1, 2, 3 or 5). ‘G’ format IncOders have a reinforced internal structure. External mechanical & electrical interfaces are unchanged. Local strain relief of cables must be used in all applications with shock or vibration. Specify ‘G’ at the end of the standard Product Number.

### **Engraved Data – Extended Product Option ‘E’**

Standard IncOder Stators carry a serial number on a self-adhesive, metalized label. In some applications, a label is not acceptable and product data must be engraved. Engraved data includes part number & serial number on exterior faces of housing. Specify ‘E’ at the end of the standard Product Number.

### **Cold Temperature Option – Extended Product Option ‘12CT’ or ‘24CT’ (58mm only)**

Standard IncOders have a lower operating temperature limit of -45°C. For prolonged or frequent operation at temperatures <-45°C, a cold temperature version (lower operating temperature of -60°C) should be specified using the 12CT or 24CT Extended Product Option in the voltage supply section of the part number. For operating temperatures <-60°C consult Celera Motion.

### **High Temperature Option – Extended Product Option ‘5HT’ (58mm only)**

Standard IncOders have an upper operating temperature limit of +85°C. For prolonged or frequent operation at temperatures >85°C, a high temperature version (upper operating temperature of +105°C) should be specified using the 5HT Extended Product Option in the voltage supply section of the part number. Only available with SS11-9, SPI, ASI1-2 & BiSS-C communications. Careful selection of the appropriate cable is required for high operating temperatures. Generally, the high temperature cable INC-CAB3-2-HT should be specified or the AFL5/ALF52 integral cable. For operating temperatures >105°C consult Celera Motion.



## 4.8 Extended Product Range

### Prolonged Immersion, Salt Spray or Extreme Dust Conditions – Extended Product Option ‘C’

Standard IncOders will operate reliably if subject to moist, wet, dusty or salt spray conditions for short or infrequent periods. Such conditions include immersion in mineral oil or water – depending on cable connection selected. If the IncOder will be subject to prolonged periods of high levels of condensing moisture, immersion in water, exposure to salt atmospheres or potential abrasion by dust or grit then Extended Product Option C is recommended. This option provides additional protection to the IncOder’s sensing faces using an acrylic conformal coat. This option is not required if immersion is in mineral oil. This option is not required (because it is already included) if a sealed version of integral axial cable is selected e.g. AFL2, AFL32, AFL42 or AFL52. Specify ‘C’ at the end of the standard Product Number.

### High Pressure Option – Extended Product Option ‘V’ (58mm only)

If operation at high pressures is needed (for example, sub-sea equipment submerged in mineral oil) then the use of Extended Range Product Option ‘V’ is recommended. Maximum recommended operating pressure is 4,000psi or 280Bar. Higher operating pressures may be possible subject to qualification by the user in host equipment. ‘V’ designated products undergo a hard epoxy encapsulation process which ensures absence of internal voids. Specify ‘V’ at the end of the standard Product Number.



# 4.9 Measurement & Electrical Data (58mm)

## Measurement & Elec. Data for Digital Comms Interfaces - Product Options SSI-9, SPI, ASI1, ASI2 & BiSS-C

INC-x-58				
Measurement	Absolute over 360°. Note this is true absolute - no motion required at start up			
Resolution (121001 Product Option)	12bits	4,096counts per rev	316.4arc-secs	1536micro-rads
Resolution (141001 Product Option)	14bits	16,384counts per rev	79.1arc-secs	384micro-rads
Resolution (161001 Product Option)	16bits	65,536counts per rev	19.77arc-secs	96micro-rads
Resolution (171001 Product Option)	17bits	131,072counts per rev	9.89arc-secs	48micro-rads
Resolution (181001 Product Option)	18bits	262,144counts per rev	4.94arc-secs	24micro-rads
Resolution (191001 Product Option)	19bits	524,288counts per rev	2.47arc-secs	12micro-rads
Resolution (201001 Product Option)	20bits	1,048,576counts per rev	1.24arc-secs	6micro-rads
Repeatability	+/-1			count
Static Accuracy over 360°	≤75arc-seconds or 0.36milliradians			
Internal Position Update Period	<0.1			millisecond
Thermal Drift Coefficient	≤0.50			ppm/K Full-Scale
Max. Speed for Angle Measurement	10,000			r.p.m.
Data Outputs	RS422 Compatible, supports SSI (Serial Synchronous Interface), ASI (asynchronous serial interface), SPI or BiSS-C			
Power Supply	5VDC(4.5-32VDC) or 12VDC (4.5-32VDC) or 24VDC (4.5-32VDC)			VDC
Current Consumption	<100 (typically <75 and does not change significantly with voltage supply)			milliAmp
Reverse Polarity	PSU Reverse polarity protected to max. supply voltage			VDC
Connector (ACx & RCx Product Options)	Harwin Data Mate Vertical Plug 10 Way with 2 Jack Screws Type M80-500-10-42 or M80-510-10-42 or M80-540-10-42			
Mating Connector (ACx & RFCx)	Harwin Data Mate Vertical Socket Type M80-461-10-42 (alternative M80-461-10-05)			
Zero Setting	Via Connector Pin or Integral Cable - see details for set and reset in relevant Section for Connector, Cable or Comms Interface			
Power Up Time To 1st Measurement	<500			millisecond

## Measurement & Electrical Data for A/B/Z Pulses Comms Interfaces - Product Option ABZ1-6

INC-x-58				
Measurement	Incremental with reference mark. Position of reference mark programmable by user.			
Resolution	As above (limited to 17-bits) - resolution defined as one edge of A/B pulse train			
Repeatability	+/-1			count
Static Accuracy over 360°	≤75arc-seconds or 0.36milliradians			
Internal Position Update Period	<0.1			millisecond
Thermal Drift Coefficient	≤1			ppm/K Full-Scale
Max. Speed for Angle Measurement	10 to 16bits = 7200r.p.m. 17bits = 3600r.p.m.			
Data Outputs	A/B pulses with Z pulse ref. Z position settable from connector/cable. Z pulse width selectable by Product Option/ Part Number.			
Power Supply	5VDC±10% or 12VDC (8-32VDC) or 24VDC (8-32VDC)			VDC
Current Consumption	<150 (does not vary significantly with supply voltage)			milliAmp
Reverse Polarity	PSU Reverse polarity protected to max. supply voltage			VDC
Connector (ACx & RFCx Product Options)	As above - resolution defined as one edge of A/B pulse train			
Mating Connector (ACx & RFCx)	Harwin Data Mate Vertical Socket Type M80-461-10-42 (alternative M80-461-10-05)			
Z Position Setting	Via Connector Pin or Integral Cable - see details for set and reset in relevant Section for Connector, Cable or Comms Interface			
Power Up Time To 1st Measurement	<500			millisecond



## Environmental Data

INC-x-58		
<b>Operating Temp.</b>	Minus 45 to +85 Minus 60 to +85Celsius for 12VCT & 24VCT Product Option. Minus45 to +105Celsius max. for 5HT Product Option Operation outside limits to be qualified by user.	Celsius
<b>Storage Temp.</b>	Minus 55 to +125 (Minus 60 to +125 for 24CT Product Option)	Celsius
<b>Temperature Shock</b>	MIL-STD-810G, Method 503.5, Procedure I-B (T1=-40 °C, T2=55 °C.)	
<b>IP Rating - Rotor &amp; Stator</b>	IP67 for <60 minutes & 1m depth (Installed with mechanically protected connector or AFL1-5 or VFL1-5 Product Options) For additional protection for long term immersion at depth, specify product option AFL2-52 or VFL2-52 Product Option For immersion at depths of >100m select Extended Range High Pressure Option	
<b>IP Rating - Connector</b>	IP50 (ACx or RCx Product Option). See Section 4.7 for IP rating of AFLx & VFLx Product Option	
<b>Humidity</b>	RH 0-99% standard. Select Extended Range Option C & appropriate connector for condensing humidity or long term immersion	
<b>Salt Fog</b>	(Installed with protected cable/connector or any integral axial cable) Complies with DEF STAN 00-35 Pt. 3 Iss. 4, Test CN2 Salt Mist Test. Select Extended Range Option C and appropriate connector for environments with significant exposure to salt fog	
<b>Bio Hazards</b>	(Installed with protected cable/connector or any integral axial cable) Complies with DEF-STAN 00-35 Pt. 4 Iss. 4 Section 11 (Hazards)	
<b>Induced Dust &amp; Sand</b>	Complies with DEF STAN 00-35 Pt3 Iss 4, Test CL25 (Turbulent Dust) Cat 1. Select Extended Range Option C and appropriate connector for environments with abrasive dust or sand.	
<b>Mechanical Impact Resistance</b>	IK07 - when installed - suitable for mechanical impacts from objects of >200grams from 1m height	
<b>Shock</b>	IEC 60068-2-27 100g for 11ms - axial & radial - suitable for most airborne, marine & armoured vehicles MIL-STD-810G, Method 516.6, Procedure I-Functional Shock - axial and radial - 40 g 11 ms, sawtooth waveform For more extreme or prolonged conditions specify Extended Product Option G & preferably Integral Axial Cable	
<b>Vibration</b>	IEC 60068-2-6 20g for 10-2000Hz - axial and radial - suitable for most high vibration & airborne environments MIL-STD-810G, Method 514.6, Procedure I - axial and radial - Category 20, for tracked vehicles For more extreme or prolonged conditions specify Extended Product Option G and preferably Integral Axial Cable	
<b>Environmental pressure range</b>	0 to 7 (i.e. vacuum to 7). See Extended Product Range High Pressure Option for higher operating pressures	Bar
<b>Max. permissible press. change rate</b>	1	Bar/second
<b>EMC Radiated Susceptibility</b>	(Installed) Complies with IEC 61000-6-2 - suitable for fitment in harsh EMC environments	
<b>EMC Radiated Emissions</b>	(Installed) Complies with IEC 61000-6-4 - suitable for fitment adjacent to EMI sensitive devices	
<b>Materials - all Product Options</b>		
<b>Rotor &amp; Stator Housings</b>	Standard range:- Al. alloy (6061-T6 or 6084-T6) with SurTec650. Sensor surfaces: FR4 grade epoxy Product Option A or S:- Alcrom finish al. alloy (6061-T6 or 6084-T6). Sensor surfaces: FR4 grade epoxy	
<b>Connector (ACx or RCx Product Option)</b>	PPS with Stainless Steel Screw Fixings and Gold & Tin Electrical Connections	
<b>Miscellaneous - all Product Options</b>		
<b>Mass Shaft Clamp Rotor (max.)</b>	43	grams
<b>Mass Plain Rotor (max.)</b>	32	grams
<b>Mass Servo Clamp Stator (AC1)</b>	43	grams
<b>Mom. of Inertia Shaft Clamp Rotor (max.)</b>	2.0E-05	Kgm <sup>2</sup>
<b>Mom. of Inertia Plain Rotor (max.)</b>	1.8E-05	Kgm <sup>2</sup>
<b>MTBF</b>	0.22 failures per 1M hours based on MIL-HBK-217+ method for ground military vehicles at 20Celsius average	
<b>MTBF</b>	0.35 failures per 1M hours based on MIL-HBK-217+ method for naval sheltered at 35Celsius average	
<b>Hazardous materials</b>	Standard range - Hazardous materials not used. RoHS compliant. RoHS certificate available. REACH statement available.	
<b>Outgassing materials</b>	Complies with NASA class'n as low outgas mat. with TML <1% & CVCM <0.1% at 125C & 24hrs vacuum to ASTM E-595-90	
<b>ITAR classification</b>	Not ITAR controlled. No ITAR components	
<b>Approvals</b>	Flammability Rating UL94V-0. Standard range - RoHS compliant - RoHS certificate available. REACH statement available.	
<b>Marking</b>	Zettlex, logo, CE & UL94V-0 printed on Rotor & Stator faces; Serial No. labelled on exterior diameter of Stator housing Extended Product Range Option E - engraved serial number and part number on exterior faces of Stator & Rotor	
<b>Country of Manufacture</b>	UK	
<b>Export Licence Requirements</b>	Not required for standard product options	

# 4.11 Measurement, Electrical & Environmental Data (37mm)

## Measurement, Electrical, Environmental & Material Data for 37mm IncOder

Measurement				
Measurement	Absolute over 360°. Note this is true absolute - no motion required at start up			
Resolution (101001 Product Option)	10bits	1,024counts per rev	1265.6arc-secs	6144micro-rads
Resolution (121001 Product Option)	12bits	4,096counts per rev	316.4arc-secs	1536micro-rads
Resolution (141001 Product Option)	14bits	16,384counts per rev	79.1arc-secs	384micro-rads
Resolution (161001 Product Option)	16bits	65,536counts per rev	19.77arc-secs	96micro-rads
Resolution (171001 Product Option)	17bits	131,072counts per rev	2.47arc-secs	48micro-rads
Repeatability	+/-1			count
Static Accuracy over 360°	<150arc-seconds or <0.73milliradians			
Internal Position Update Period	<0.1			millisecond
Thermal Drift Coefficient	≤1.0			ppm/K Full-Scale
Max. Speed for Angle Measurement	10,000			r.p.m.
Max. Physical Speed	10,000			r.p.m.
Electrical				
Data Outputs	RS422 Compatible, supports SSI (Serial Synchronous Interface), ASI (asynchronous serial interface), SPI or BiSS-C.			
Power Supply	5VDC (4.5-8VDC) or 12VDC (4.5-14VDC)			VDC
Current Consumption	<100 (typically <75 and does not change significantly with voltage supply)			milliAmp
Reverse Polarity	PSU Reverse polarity protected to max. supply voltage			VDC
Zero Setting	Zero Set or Reset to factory value via Electronics Module			
Power Up Time To 1st Measurement	<500			millisecond
Environment				
Operating Temp.	Minus 45 to +85 (+65 at >8VDC power supply) Operation outside limits to be qualified by user. At temperatures >85Celsius, duration should be minimized.			Celsius
Storage Temp.	Minus 55 to +125			Celsius
Temperature Shock	MIL-STD-810G, Method 503.5, Procedure I-B (T1=-40 °C, T2=55 °C.)			
IP Rating - Rotor & Stator	IP67 for <60 minutes & 1m depth			
Humidity	RH 0-99% non-condensing - <i>but unaffected by occasional condensation</i>			
Salt Fog	Complies with DEF STAN 00-35 Pt 3 Iss. 4, Test CN2 Salt Mist Test			
Bio Hazards	Complies with DEF-STAN 00-35 Pt 4 Iss. 4 Section 11 (Hazards)			
Induced Dust & Sand	Complies with DEF STAN 00-35 Part 3 Issue 4, Test CL25 (Turbulent Dust) Cat 1			
Shock	IEC 60068-2-27 100g for 11ms - axial & radial - <i>suitable for most airborne, marine &amp; armoured vehicles</i> MIL-STD-810G, Method 516.6, Procedure I-Functional Shock - axial and radial - 40 g 11 ms, sawtooth waveform			
Vibration	IEC 60068-2-6 20g for 10-2000Hz - axial and radial - <i>suitable for most high vibration &amp; airborne environments</i> MIL-STD-810G, Method 514.6, Procedure I - axial and radial - Category 20, for tracked vehicles			
Environmental pressure range	0 to 4 ( <i>in other words vacuum to 4</i> )			Bar
Max. permissible press. change rate	1			Bar/second
EMC Radiated Susceptibility	(Installed) Complies with IEC 61000-6-2 - <i>suitable for fitment in harsh EMC environments</i>			
EMC Radiated Emissions	(Installed) Complies with IEC 61000-6-4 - <i>suitable for fitment adjacent to EMI sensitive devices</i>			
Miscellaneous				
Mass Set-Screw Rotor (max.)	10 (for 8mm bore)			grams
Mass Plain Rotor (max.)	7 (for 8mm bore)			grams
Mass Screw Mount Stator (max.)	20 (for 8mm bore)			grams
Mass E-Module in Housing	25			grams
MTBF	0.22 failures per 1M hours based on MIL-HBK-217+ method for ground military vehicles at 20Celsius average			
MTBF	0.35 failures per 1M hours based on MIL-HBK-217+ method for naval sheltered at 35Celsius average			
Hazardous materials	Standard range - Hazardous materials not used. RoHS compliant. RoHS certificate available. REACH statement available.			
Outgassing materials	Complies with NASA class'n as low outgas mat'l. with TML <1% & CVCM <0.1% at 125C & 24hrs in vacuum to ASTM E-595-90			
ITAR classification	Not ITAR controlled. No ITAR components.			
Approvals	Flammability Rating UL94V-0. Standard range - RoHS compliant - RoHS certificate available. REACH statement available.			
Marking	Zetlex, logo, CE & UL94V-0 printed on Rotor & Stator faces; Serial Number label. Extended Product Range Option E - engraved serial number and part number on exterior faces of Stator & Rotor			
Country of Manufacture	UK			
Export Licence Requirements	Not required for standard product options			

# 5. Customised Products

Celera Motion often modify IncOders to specific OEM requirements. Potential changes include :-

- size, mechanical mounts and housing materials
- voltage supplies & electrical outputs
- measurement performance
- connectors, cables & immersion protection
- temperature range – notably to -100Celsius and below
- low weight or low inertia.

Consult Celera Motion or your local representative for further information. Typically, customised products are an economical option in volumes of >200 units/year. Engineering/tooling charges may apply depending on order quantity. Some examples and guidance on suitable dimensions are shown below.



Ultra lightweight (13gram) miniature unit.



Custom housing with chromate surface finish & integral cable for remotely controlled gimbal.



Compact unit for high shock & vibration environment with integral cable.



Electrically duplex lightweight encoder with collar clamp.

To minimise tooling charges, the OD of Stator & Rotor should preferably be based on a standard size with a corresponding ID. For 37 or 58mm nominal devices, should not be less than the dimensions shown below:-

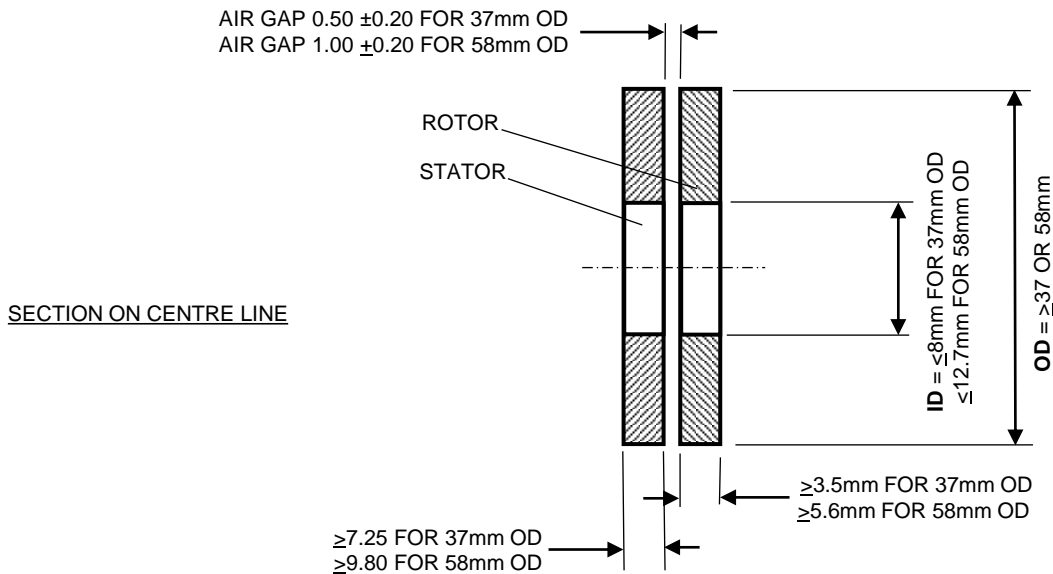

The IncOder range offers 5 different Communication Interfaces:-

- Synchronous Serial Interface – see Section 6.4 (Product Options SSI1-9)
- Asynchronous Serial Interface – see Section 6.5 (Product Option ASI1-2)
- Serial Peripheral Interface – see Section 6.6 (Product Option SPI1)
- A/B/Z pulses – see Section 6.7 (Product Option ABZ1 etc.)
- BiSS-C – see Section 6.8 (Product Options BIS3)

All digital Communication Interfaces conform to the RS422 Standard. Note that for all Communications Interfaces, DATA & CLOCK inputs are not terminated with load resistors.

## 6.1 Output Resolution

The IncOder range offers various Options for the resolution of the output data. The required digital resolution is simply specified using the relevant Product Option – see Section 8.

**INC - X - XXX - XXXXXX - XXXX - XXXX - X - XXX**

<b>Resolution</b> measured in bits.	
10 Bits <b>101001</b>	*18 Bits <b>181001</b>
11 Bits <b>111001</b>	*19 Bits <b>191001</b>
12 Bits <b>121001</b>	*20 Bits <b>201001</b>
13 Bits <b>131001</b>	Alternatively, for ABZ pulse output only, specify number of pulses per rev up to a max of 32,768 e.g. <b>P32678</b>
14 Bits <b>141001</b>	
15 Bits <b>151001</b>	
16 Bits <b>161001</b>	
17 Bits <b>171001</b>	
	*58mm only

## 6.2 Multi-Turn or Single Turn

The default electrical output from an IncOder is over 1 rev. For multi-turn devices please contact Celera Motion or your local rep.

## 6.3 Zero Point Set & Reset for Digital Outputs

### Product Options - SSI1-9, SPI1, ASI1-2, BIS3 (58mm)

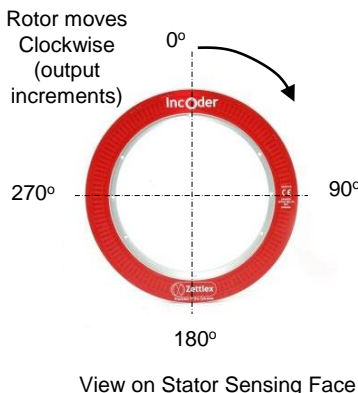

The Zero Point is the datum from which angle is measured. As supplied, the IncOder carries a factory Zero Point setting. The Zero Point is very roughly at 12 o'clock (near the 'O' of the printed 'IncOder'). The Zero Point can be changed using the Zero Set and Zero Reset lines on the IncOder's electrical interface. The Zero Set signal will set the current IncOder position as the Zero Point (held in memory when power removed). Zero Reset signal will reset the Zero Point to the factory setting (held in memory when power removed). To use, the relevant connection should be connected to electrical ground (<0.5V) for 5 seconds at power up but left unconnected (i.e. open circuit) during operation. (For 37mm see Section 7.2)

## 6.4.1 Generic Protocol Definition

SSI is a widely used serial interface between position sensors and controllers. It is based on the RS-422 hardware standard and implements a differential output for the DATA and a differential input for the CLOCK. (Note that DATA outputs and CLOCK inputs are not terminated with load resistors.)

Synchronous SSI uses a clock sequence from a controller to initiate the transmission of position data from the sensor (a Read Cycle), with the latest position data (see Section 4.9/4.11 for internal position update rate) available for transmission after each SSI Read Cycle is completed. See timing information below:-

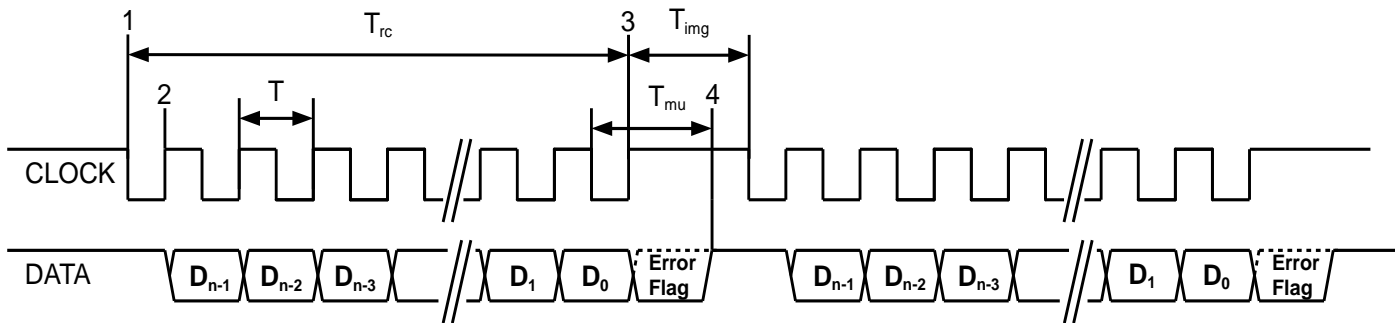

T: Clock Period ( $1/T = 100 \text{ kHz to } 2 \text{ MHz}$ )

T<sub>rc</sub>: Read Cycle time: This is defined as  $(n \times T) + (0.5 \times T)$

T<sub>mu</sub>: Message Update time. The time from last falling edge of clock to when new data is ready for transmission.

T<sub>mu</sub> = 20us +/- 1 us. The DATA line will be HIGH after this time indicating a new Read Cycle can be started.

T<sub>img</sub>: Intermassage Gap time. Must be > T<sub>mu</sub> otherwise position data will be indeterminate.

n: The number of bits in the message (not including the Error Flag).

In idle state CLOCK and DATA are both HIGH

### Notes:

1. The first falling edge after T<sub>mu</sub> starts the Read Cycle and the transfer of data.
2. Each rising edge of the CLOCK transmits the next data bit of the message, starting with D<sub>n-1</sub>.
3. After the last rising edge of the clock sequence, the data line is set by the Error Flag (if supported) for the period T<sub>mu</sub> - 0.5xT
4. After T<sub>mu</sub>, the latest position data is now available for transmission in the next Read Cycle – see Section 4.9, 4.11 for position update rate.

SSI can support a variety of protocols in which data is transmitted depending on the requirements of the SSI controller. **IncOder can be supplied with any of the following protocols – just choose what you need by using the relevant Product Option when ordering (see Section 8).** If the protocol you require is not listed here then please consult Celera Motion or your local representative.

## 6.4.2 SSI Protocols for Single Turn IncOders – Product Options SSI1-9

### SSI1 (n = 24)

*Most popular choice*

<b>D23</b>	PV	Position Valid Flag. Set to 1 when data is valid, otherwise 0 (the inverse of the ERROR FLAG).
<b>D22</b>	ZPD	Zero Point Default. Set to 1 when the Zero Point is at Factory Default, otherwise 0
<b>D21-D0</b>	PD[21:0]	Binary position data. If resolution of device is less than 22 bits, then the MSBs of this field are set to 0. The LSB of this field is in D0. When PV is 0, PD[21:0] value is not defined.

### SSI2 (n = 24)

<b>D23-D2</b>	PD[21:0]	Binary position data. If resolution of device is less than 22 bits, then the MSBs of this field are set to 0. The LSB of this field is in D2. When Alarm bit is 1, PD[21:0] value is not defined.
<b>D1</b>	P	Parity Bit 0 indicates an even number of 1's in data (D23-D2), 1 indicates an odd number of 1's in data.
<b>D0</b>	A	Alarm Bit – 0 indicates normal operation, 1 indicates error condition.

### SSI3 (n = 16)

<b>D15-D0</b>	PD[15:0]	Binary position data. When ERROR FLAG is 1, PD[15:0] value is not defined.
---------------	----------	--

Note: the use of SSI3 limits the measurement resolution to a maximum of 16bits.

### SSI4 (n = 32)

<b>D31</b>	PV	Position Valid Flag. Set to 1 when position data valid, otherwise 0 (inverse of ERROR FLAG).
<b>D30</b>	ZPD	Zero Point Default. Set to 1 when the Zero Point is at Factory Default, otherwise 0
<b>D29-D11</b>	PD[18:0]	Binary position data. If resolution of device is less than 19 bits, then the MSBs of this field are set to 0. The LSB of this field is in D11. When PV is 0, PD[18:0] value is not defined.
<b>D10-D0</b>	TS[10:0]	Time stamp data. The value of the Time Stamp counter when the position was measured. This data is always valid. The Time Stamp counter is a continuously incrementing counter in the range: 0.00ms to 20.47ms (at which point it restarts at 0.00ms). It has a resolution of 10us, with an accuracy better than 1% (based on the system oscillator).

Note: the use of SSI4 limits the measurement resolution to a maximum of 19bits.

### SSI5 (n = 16)

<b>D15-D0</b>	PD[15:0]	Gray code, position data. When ERROR FLAG is 1, PD[15:0] value is not defined.
---------------	----------	--

Note: the use of SSI5 limits the measurement resolution to a maximum of 16bits.

## SSI6 (n = 32)

<b>D31-D24</b>	CRC[7:0]	CRC-8: To verify transmission, calculate the CRC of the bottom 24 bits of the message. The resulting CRC should be the same as the received CRC field. The following parameters define CRC-8: Polynomial 0x97 Initial data 0x00 MSB First (not reversed) No final XOR calculation
<b>D23</b>	PV	Position Valid Flag. Set to 1 when position data is valid, otherwise 0 (the inverse of the ERROR FLAG).
<b>D22</b>	ZPD	Zero Point Default. Set to 1 when the Zero Point is at Factory Default, otherwise 0
<b>D21-D0</b>	PD[21:0]	Binary position data. If resolution of device is less than 22 bits, then the MSBs of this field are set to 0. The LSB of this field is in D0. When PV is 0, PD[21:0] value is not defined.

## SSI7 (n = 30)

<b>D29-D24</b>	-	Data always 0.
<b>D23-D2</b>	PD[21:0]	Binary position data. If resolution of device is less than 22 bits, then the MSBs of this field are set to 0. The LSB of this field is in D2. When Alarm bit is 1, PD[21:0] value is not defined.
<b>D1</b>	P	Parity Bit 0 indicates an even number of 1's in data (D23-D2) 1 indicates an odd number of 1's in data.
<b>D0</b>	A	Alarm Bit – 0 indicates normal operation, 1 indicates error condition.

## SSI8 (n = 18)

<b>D17-D0</b>	PD[17:0]	Gray code, position data. When ERROR FLAG is 1, PD[17:0] value is not defined.
---------------	----------	--

Note: the use of SSI8 limits the measurement resolution to a maximum of 18bits.

## SSI9 (n = 32)

<b>D31</b>	PV	Position Valid Flag. Set to 1 when position data valid, otherwise 0 (inverse of ERROR FLAG).
<b>D30</b>	ZPD	Zero Point Default. Set to 1 when the Zero Point is at Factory Default, otherwise 0
<b>D29-D11</b>	PD[18:0]	Binary position data. If resolution of device is <19bits, then the MSBs of this field are set to 0. The LSB of this field is in D11. When PV is 0, PD[18:0] value is not defined.
<b>D10-D0</b>	TS[10:0]	Time stamp data. The value of the Time Stamp counter when the position was measured. This data is always valid. The Time Stamp counter is a continuously incrementing counter in the range: 0.00ms to 2.047ms (at which point it restarts at 0.00ms). It has a resolution of 1us, with an accuracy better than 1% (based on the system oscillator).

Note: the use of SSI9 limits the measurement resolution to a maximum of 19bits.

## 6.5.1 ASI Protocol Overview

This section describes the communications interface for IncOders with ASI1 and ASI2 serial protocols. Data is transmitted by the IncOder continuously formatted into Frames. Each Frame consists of a number of 8 bit data words. Each 8 Bit data word (or byte) is transmitted from a standard UART using N-8-1 (no parity, 8 data bits, 1 stop bit). ASI1 has a Baud rate of 230400 and ASI2 has a Baud rate of 921600. See below for the data format of each transmitted data word. ASI1 Frames are transmitted at a rate of 3.33kHz nominal. ASI2 Frames are transmitted at a rate of 10kHz nominal (same rate as Internal Position Update Period).

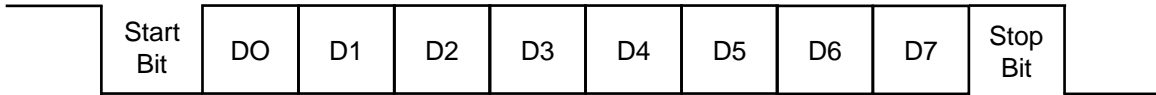

## 6.5.2 ASI Protocols for Single Turn IncOders – Product Options (ASI1-2)

The following is the Asynchronous Serial Data protocol specified with the ASI1 or ASI2 Product Option. Each frame is defined as 6 bytes and the data format is defined as follows:

First byte (transmitted first):

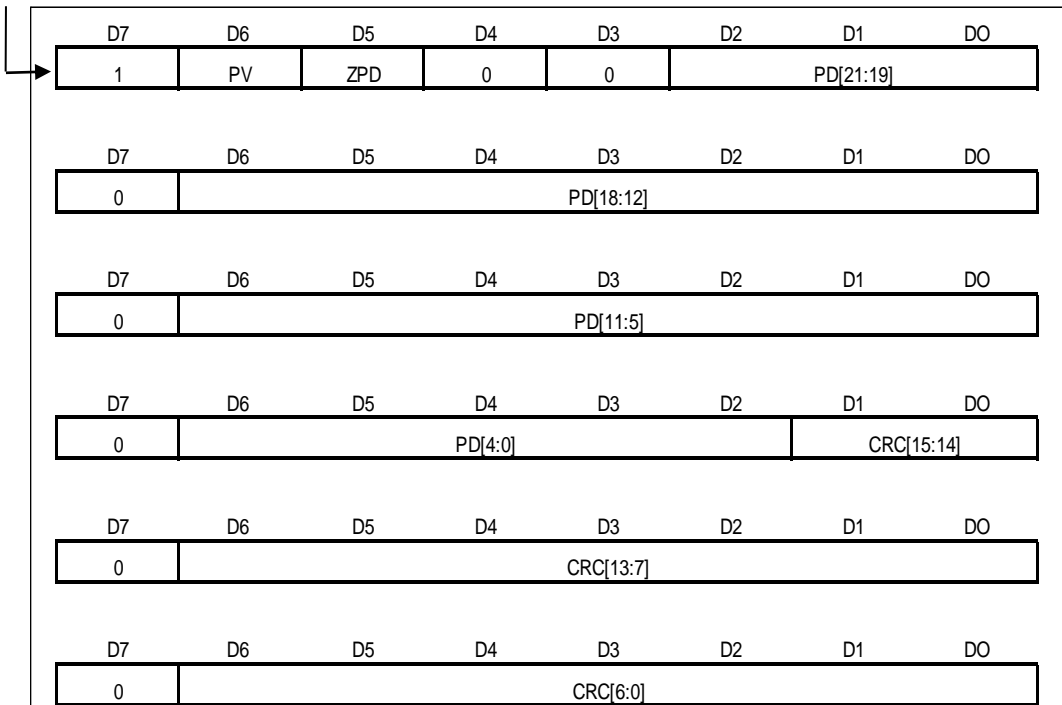

### Data Definition for Asynchronous Serial Interface

- PV      Position Valid flag. Set to 1 when data is valid, otherwise set to 0
- ZPD     Zero Point Default. Set to 1 when the Zero Point is at Factory Default, otherwise set to 0.
- PD[21:0] IncOder Position Data. If resolution of device is less than 22 bits then the MSBs of this field are set to 0.  
When PV is 0, PD[21:0] value is not defined.
- CRC[15:0] CRC-16: To verify transmission, calculate the CRC of all 48 bits of the message but with CRC[15:0] set to 0.  
The resulting 16 bit CRC result should be the same as the received CRC[15:0].  
Use the following CRC-16 parameters:  
  - Polynomial      0x8005
  - Initial data     0x0000
  - MSB first (not reversed)
  - No final XOR calculation.



## 6.6.1 SPI Protocol Overview

This section describes the communications interface for IncOders with SPI1 and SPI31 (Serial Peripheral Interface) serial protocols. SPI is a widely used serial interface between micro processors/controllers and peripherals. SPI uses a clock sequence from a master to control the transmission of data from the IncOder. IncOders with SPI data interface conform to the RS422 hardware specification.

Note that the DATA outputs and the CLOCK inputs are not terminated with load resistors.

SPI Clock Polarity is defined so that the CLOCK idle state is HIGH and the Clock Phase is defined so that the data is captured on the falling edge of CLOCK, and the data is propagated on the rising edge of CLOCK. This is commonly depicted as CPOL=1, CPHA=0 (also depicted as UCCKPL=1, UCCKPH=1).

Clock rate is 100kHz to 5MHz.

The following sections define the communication protocol.

## 6.6.2 SPI Protocol for Single Turn IncOders – Product Option SPI1

The SPI1 IncOder protocol specifies that each data frame consists of 6 bytes of data (each of 8 bits, 48 bits in total) containing the position, status flags and CRC.

### Data Definition for IncOder SPI1 Protocol

<b>D47-D33</b>	SBZ	These bits will always be Zero.
<b>D32</b>	ZPD	Zero Point Default flag. Set to 1 when the Zero Point is at Factory Default, otherwise 0.
<b>D31</b>	PV	Position Valid Flag. Set to 1 when position data is valid, otherwise 0.
<b>D30</b>	PS	Position Synchronised flag. Set to 1 when the position measurement was triggered by a previous SPI Frame. Set to 0 when the position measurement was triggered by a Measurement Time-out (see Section 6.6.3 Case 1). Use this flag to ensure that the IncOder has synchronised position measurements to the SPI Frames (Case 1, Section 6.6.3).
<b>D29-D8</b>	PD[21:0]	Binary position data. If resolution of device is less than 22 bits, then the most significant bits of this field are set to 0. The LSB of this field is in D0. When PV is 0, PD[21:0] value is not defined.
<b>D7</b>	SD	Stale Data flag. Set to 1 when the position data has been transmitted at least once before. Set to 0 when the position data has not been transmitted before. Use this flag to detect when a new measurement has been completed (Case 2, Section 6.6.3).
<b>D6-D0</b>	CRC[6:0]	Cyclic Redundancy Checksum. 7 Bit CRC: Polynomial 0x5B, Initial data 0x0000, MSB first (not reversed), No Final XOR.

Note – the CRC is generated from bits D7 through D32. It is calculated using a 32 bit word (or 4 bytes) with D7 shifted in to the Least Significant Bit and the 6 Most Significant Bits set to '0' as required.

## 6.6.3 SPI Timing Information

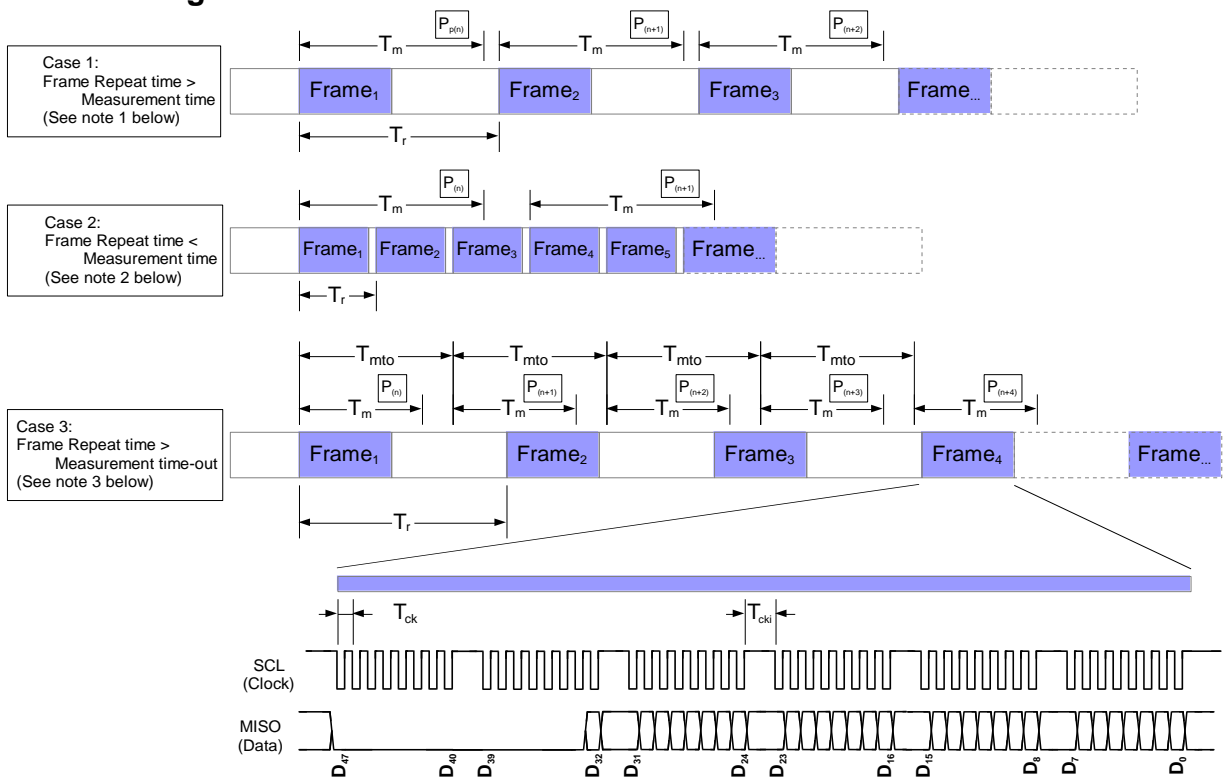

### Timings determined by the Controller (SPI Master):

- $T_{ck}$  Clock period (1/T = 100kHz to 5MHz).
- $T_{cki}$  Clock Idle Period. Time between bytes during which CLOCK is idle.  $T_{cki}$  should be  $< T_{ckimax} = 10\mu s$
- $T_r$  Frame Repetition period.

### Timings defined by the IncOder (SPI Slave):

- $T_m$  Position Measurement time. The time from the start of a position measurement to when the position and status is ready for transmission.  $90\mu s \leq T_m \leq 95\mu s$
- $T_{mto}$  Position Measurement Time-out. The time after a position measurement has been triggered that the IncOder will automatically trigger a new measurement.  $135\mu s \leq T_{mto} \leq 145\mu s$ .

### Notes:

- The IncOder will always attempt to trigger a new position measurement when a new SPI frame is started by the host. This will always be the case when  $T_r$  is greater than  $T_m$  and less than  $T_{mto}$ .
- If a position measurement has already been triggered when a new SPI frame is started by the host, then a new position measurement will not be re-triggered. This may be the case when  $T_r$  is less than  $T_m$ .
- If the Host does not start a new SPI frame within time  $T_{mto}$  from the previous frame (the case when  $T_r$  is greater than  $T_{mto}$ ), then the IncOder will automatically trigger a new position measurement.
- In all cases, the IncOder will transmit the most recently completed measured position and status (see table below).
- When CLOCK is idle for at least  $T_{ckimax}$ , then the IncOder SPI interface will reset. The first falling edge on CLOCK after  $T_{ckimax}$  will start the transmission of a new frame. This can be useful if the SPI host and slave (IncOder) lose Frame/Byte synchronisation (detected by invalid CRC).

Frame Number	Position transmitted (Case 1)	Position transmitted (Case 2)	Position transmitted (Case 3)
Frame 1	$P_{(n-1)}$	$P_{(n-1)}$	$P_{(n-1)}$
Frame 2	$P_{(n)}$	$P_{(n-1)}$	$P_{(n)}$
Frame 3	$P_{(n+1)}$	$P_{(n-1)}$	$P_{(n+1)}$
Frame 4		$P_{(n)}$	$P_{(n+3)}$
Frame 5		$P_{(n)}$	

## 6.7 A/B/Z Pulse Interface – Product Options ABZ1 to ABZ6 (58mm IncOder only)

IncOders with A/B/Z pulses are often used as velocity or brushless motor encoders. A/B/Z pulse IncOders provide cyclical outputs as the encoder rotates. Streams of pulses are arranged in phase quadrature for direction sensing. The Z-reference or 'index' pulse is triggered once per turn. There are 6 Product Options:-

**Product Option ABZ1 - RS422 with 90° width Z reference**  
**Product Option ABZ2 - RS422 with 180° width Z reference**

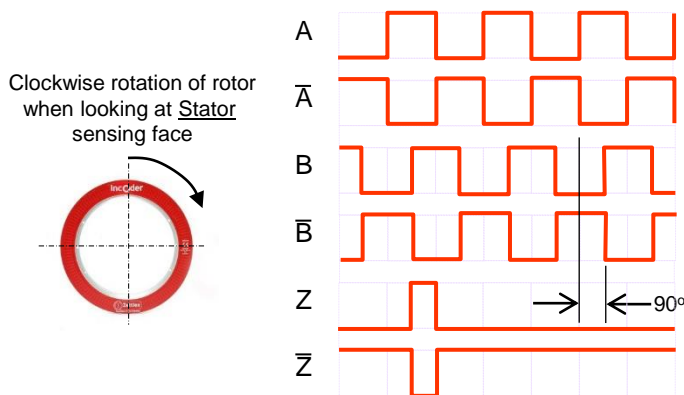

A leads B for clockwise rotation of rotor  
 Phasing: 90° electrical  
 Symmetry: 180° electrical  
 Max. pulse frequency: 2MHz  
 High signal: >2.5V  
 Low signal: <0.5V  
 Max. output load: 30mA  
 Diagram shows 90° width Z reference (ABZ1)

**Product Option ABZ3 - Push-Pull (TTL) with 90° width Z reference**  
**Product Option ABZ4 - Push-Pull (TTL) with 180° width Z reference**  
**Product Option ABZ5 - Push-Pull (HTL) with 90° width Z reference**  
**Product Option ABZ6 - Push-Pull (HTL) with 180° width Z reference**

Push-Pull devices may be run in antivalent mode (shown above) or single ended mode (shown below).

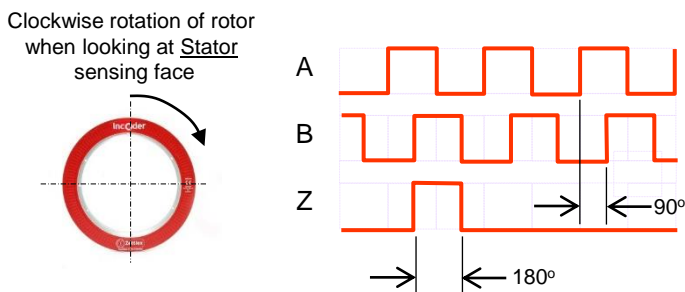

A leads B for clockwise rotation of rotor  
 Phasing: 90° electrical  
 Symmetry: 180° electrical  
 Max. pulse frequency: 2MHz  
 High signal: >Vsupply – 2V (HTL) or >4.5V (TTL)  
 Low signal: <0.2V  
 Max. current: 30mA  
 Diagram shows 180° width Z reference (ABZ4 or 6)

Note: 1 edge = 1 count or 1 bit. 4 counts per pulse. Readers should be set to 4x resolution for full resolution.

**Z Reference Position:** The factory set Z Reference Position is at +/-5° of the Rotor and Stator dowel positions at 12 o'clock (near the 'O' of the printed 'IncOder'). Z Reference Position may be changed using the Z Set or Z Reset lines on the IncOder's electrical interface (see Section 6.3 or 7.1).

**Setting Z Reference Position:** Z Set signal sets the current position as Z Reference Position. This is held in memory when power removed. Z Reset signal will reset the Z Reference Position to factory setting (held in memory when power removed). To use, the relevant connection should be connected to electrical ground (<0.5V) for at least 5 seconds at power up but left unconnected (i.e. open circuit) during normal operation (see Section 6.3 or 7.1).

**Error Signalling:** IncOders carry out various self checks. If an error is detected, then an error signal is generated. This is shown by all outputs (including differential outputs) going to a floating output state.

**Counts per rev (CPR) & Pulses per rev(PPR):** CPR may be chosen as any even integer number of bits up to 19 e.g.12 (4096CPR). PPR may be chosen up to 131,072. See Section 8 on how to select CPR or PPR from the part number. In part number, letter P in front of chosen pulses per rev indicates selection.

## 6.8.1 BiSS-C Unidirectional Protocol Overview

BiSS-C is a popular communications interface between controllers and position sensors. The IncOder BiSS-C interface is unidirectional and provides fast, compact, economic serial communications using RS422 (SSI) compatible hardware. The IncOder BiSS-C interface is a point to point configuration (a single device with a single slave), conforming to the requirements of BiSS-C Unidirectional. In this configuration, the IncOder is the only slave connected to the master (the host control system).

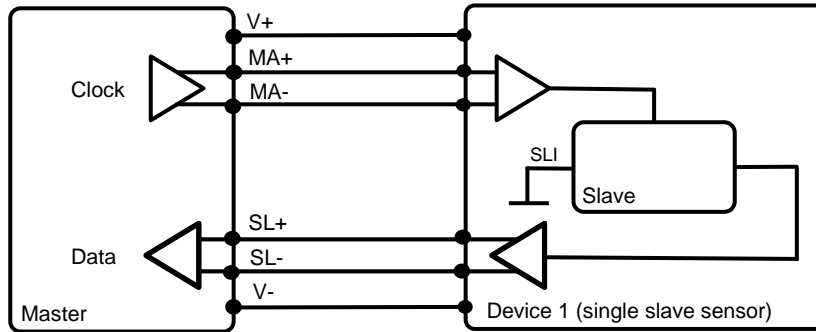

The Master transmits clock signals to the Slave via the MA line. The SL line carries the sensor data directly from the Slave back to the Master. The interface has only two unidirectional, differential lines (as the IncOder permanently connects the input SLI to '0'). Parameters for the individual data channels are specified below. These parameters can be pre-programmed in the controller and referenced via an ID or lookup table, or manually entered.

### BiSS-C Timing Parameters

Symbol	Parameter	Min.	Max.	Unit
$1/T_{MA}$	Clock Frequency	600	2000	kHz
$T_{BISS-TIMEOUT}$	BiSS Timeout	15	20	micro-seconds

The IncOder implements a “pipelined” data output. The position (and status) returned in the SCD is from the reading triggered by the previous BiSS frame (provided that the frame repetition period conforms to the requirements described for the SPI protocols - see Section 6.6).

## 6.8.2 BiSS-C Protocol for Single Turn IncOders – Product Options BIS3

### BIS3 IncOder protocol: BiSS-C Data Channel Parameters

Number of Bits (SCD length)	30 bits
Processing Time	12 Clock Cycles (12 x $T_{MA}$ micro-seconds)
Data Area Length & Alignment	24 Bits
CRC	Width: 6Bits Polynomial: 0x43 Initial Value: 0x00 Output Inverted

### Data Area Definition

MSB										LSB	
D21	D20	D19	D18	D17	...	D3	D2	D1	D0	nE	nW

- D21: Most significant bit of the position data (if IncOder resolution is <22Bits the LSBs are set to '0')
- D0: Least significant bit of the position data.
- nE: '1' = position valid
- nW: Always '1'

### Example for 18 bit resolution:

MSB										LSB	
D17	D16	D15	...	D1	D0	0	0	0	0	nE	nW

NOTE: For details regarding BIS1 and BIS2 legacy variants, please contact Celera Motion.

The following section describes the electrical supply and data connections for axial and radial connector product options (Section 4.3). Compatible cable options are detailed in Section 9.

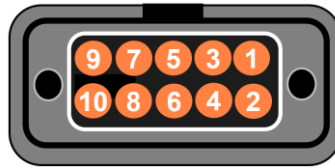

Connector Pin (For Info. Only)	Digital Output SSI, SPI & BiSS-C	Digital Output ASI	ABZ Output
10	V <sub>supply</sub>	V <sub>supply</sub>	V <sub>supply</sub>
9	0V	0V	0V
5	Data A	Data A	A
7	Data B	Data B	A complement
8	Clock A	Not Used	B
6	Clock B	Not Used	B complement
1	Zero Set	Zero Set	Z Ref Set
2	Zero Reset	Zero Reset	Z Ref. Reset
3	Reserved - NC	Reserved - NC	Z
4	Reserved - NC	Reserved - NC	Z complement

Notes:-

- Aligned with connector key as shown.
- Does not apply to \*FL\* Integral Cable Product Options. See Section 4.4.4 for FL\* Wiring Assignment.
- 27kOhm pull up resistors fitted to Zero Set, Span Set, Direction Set, Zero Reset & Reset inputs
- Reserved pins are for factory use only and should be left open circuit.

## 7.2 37mm IncOder Wire Diagram & Zero Setting

For compactness, the 37mm IncOder has a separate Electronics Module with integral cable, rather than a connector. This module is an integral part of the operation of the sensor and is required for sensor operation. The electrical connections are shown below:-

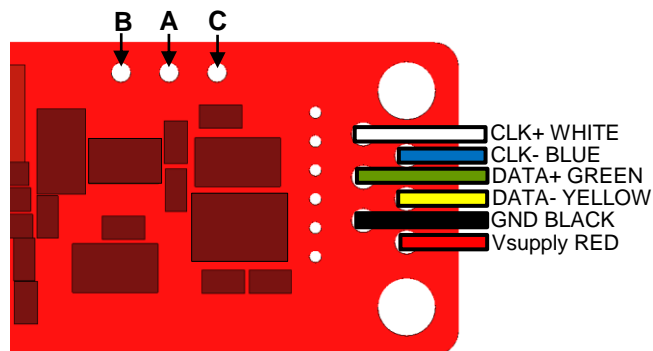

The Zero Point is the datum from which angle is measured. As supplied, the IncOder carries a factory Zero Point setting. The Zero Point can be changed using a Zero Set or Zero Reset function.

The Zero Set function will set the current IncOder position as the Zero Point (held in memory when power removed). This Zero Set function is carried out as an input to the Electronics Module. Inputs 'A' and 'B' (0.5mm diameter plated through holes identified on Electronics Module) should be electrically connected together for more than 5 seconds at power up (carried out manually using a wire jumper provided with each IncOder).

The Zero Reset signal will reset the Zero Point to the factory setting (held in memory when power removed). The Zero Reset function is carried out as an input to the Electronics Module. Inputs 'A' and 'C' (0.5mm diameter plated through holes identified on Electronics Module) should be electrically connected for more than 5 seconds at power up (carried out manually using a wire jumper provided with each IncOder).

# 8.1 Product Ordering (58mm)

**INC - X - XX.XXX - XXXXXX - XXXX - XXXX - X - X**

**Mechanical Format**

Ultra High Accuracy Servo Clamp Stator & Plain Rotor – **6H**

Ultra High Accuracy Servo Clamp Stator & Shaft Clamp Rotor – **11H**

**Finish**

**S** SurTec650

**Supply Voltage**

**5**  
**5HT** (Note 5)  
**12**  
**12CT** cold temp.  
**24**  
**24CT** cold temp.

**Outer & Inner Diameter**

**58.060** 58 & 06.0mm  
**58.100** 58 & 10.0mm  
**58.120** 58 & 12.0mm  
**58.127** 58 & 12.7mm

**Resolution**

10 Bits <b>101001</b>	18 Bits <b>181001</b>
11 Bits <b>111001</b>	19 Bits <b>191001</b>
12 Bits <b>121001</b>	20 Bits <b>201001</b>
13 Bits <b>131001</b>	PPR (Note 3) <b>PXXXXXX</b>
14 Bits <b>141001</b>	
15 Bits <b>151001</b>	
16 Bits <b>161001</b>	
17 Bits <b>171001</b>	

**Connector**

**AC1** axial connector direction 1  
**AC2** axial connector direction 2  
**RC1** radial connector direction 1  
**RC2** radial connector direction 2  
**AFL1** integral axial cable  
**AFL2** integral axial cable, sealed  
**AFL3** integral axial, high flex cable  
**AFL32** integral axial, high flex cable, sealed  
**AFL5** integral axial, PTFE / MIL spec cable  
**AFL52** integral axial, PTFE / MIL spec cable, sealed  
**VFL1** integral vertical cable  
**VFL2** integral vertical cable, sealed  
**VFL3** integral vertical, high flex cable  
**VFL32** integral vertical, high flex cable, sealed  
**VFL5** integral vert., PTFE / MIL spec cable  
**VFL52** integral vert., PTFE / MIL spec cable, sealed

**Communication Interfaces**

<b>ASI1</b> Asynch. Serial I/face 1	<b>SSI9</b> SSI Type 9 (Note 2)
<b>ASI2</b> Asynch. Serial I/face 2	<b>SPI1</b> Serial Peripheral I/face
<b>SSI1</b> SSI Type 1	<b>ABZ1</b> RS422 90° width Z
<b>SSI2</b> SSI Type 2	<b>ABZ2</b> RS422 180° width Z
<b>SSI3</b> SSI Type 3 (Note 2)	<b>ABZ3</b> Push-Pull TTL 90° width Z
<b>SSI4</b> SSI Type 4 (Note 2)	<b>ABZ4</b> Push-Pull TTL 180° width Z
<b>SSI5</b> SSI Type 5 (Note 2)	<b>ABZ5</b> Push-Pull HTL 90° width Z
<b>SSI6</b> SSI Type 6	<b>ABZ6</b> Push-Pull HTL 180° width Z
<b>SSI7</b> SSI Type 7	<b>BIS3</b> BiSS-C Type 3
<b>SSI8</b> SSI Type 8 (Note 2)	

- Notes:**
1. 1 IncOder includes 1 Stator & 1 Rotor but excludes Accessories (e.g. Servo Clamps)
  2. Maximum effective resolution limited by communications protocol – see Section 6.4.2
  3. For ABZ pulse output only – limited to 17-bits. If required resolution is not an integer bit value, specify even number of pulses per rev up to 32,768.
  4. See Section 4.8. for Extended Range Options. Note 58mm standard surface finish is SurTec650.
  5. High Temperature Option only available with SSI1-9, SPI, ASI1-2, BIS3 Comms only.

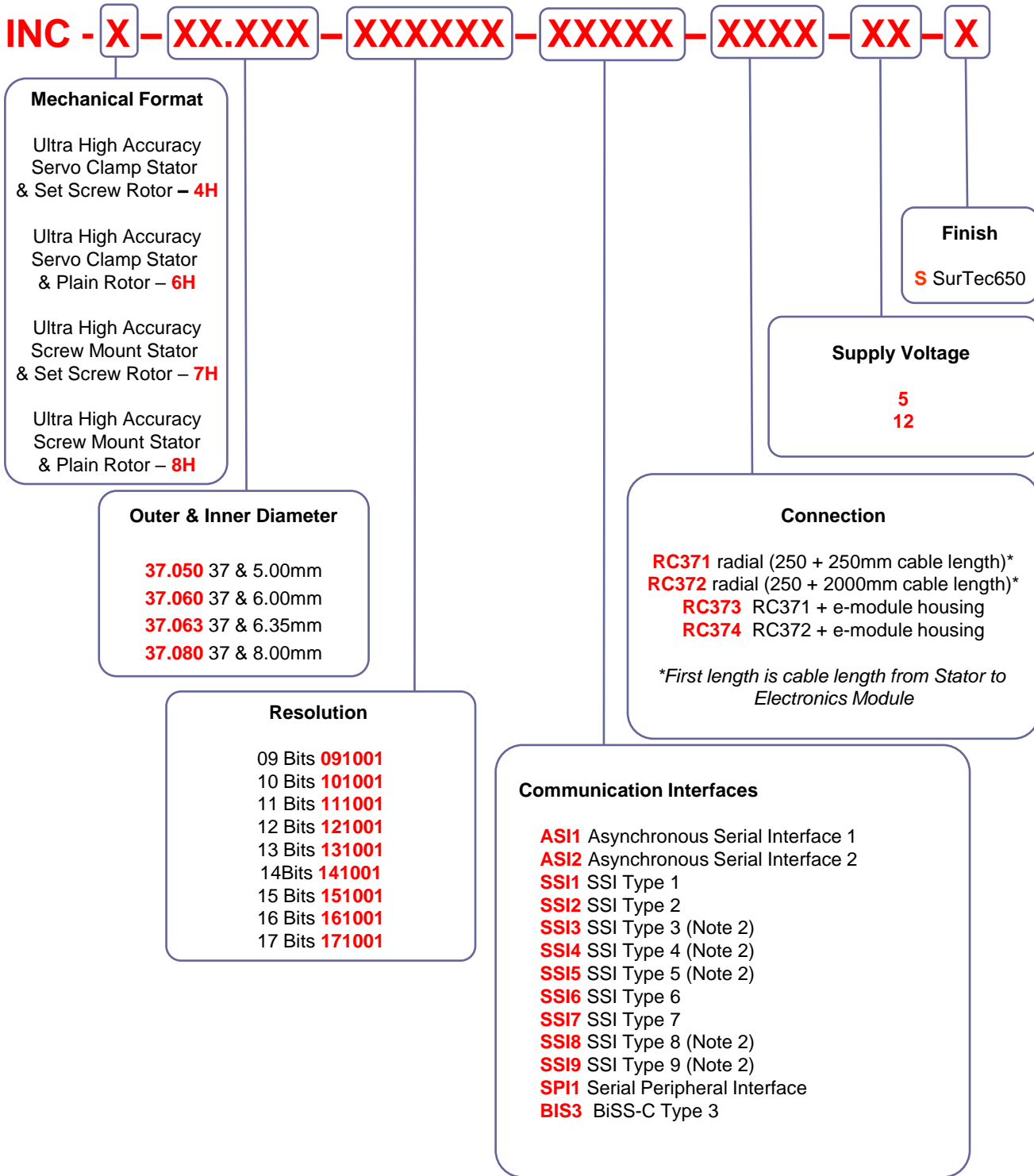

**Notes:**

- Each 37mm IncOder includes 1 Stator & 1 Rotor & 1 Electronics Module and interconnecting cables but excludes Servo Clamps – which are sold separately – please see Section 9.
- Maximum effective resolution limited by communications protocol – see Section 6.4.2.
- Only a sub-group of Extended Product Range options apply to 37mm
  - B** Extended thermal stress-screening (burn-in test) / bake-off
  - E** Engraved serial number and part number on Stator & Rotor (rather than serial label)
  - P** Use of leaded solder (rather than RoHS compliant solder)
  - C** Prolonged immersion, salt spray or extreme dust option.

**If you have difficulty in specifying what you need, please contact Celera Motion or your local representative.**

Here are some examples of part numbers:-

**INC – 6H – 58.060 – 171001 – SSI1 – AC1 – 12 – S**

Ultra High Accuracy Servo clamp stator & plain rotor, 58mm outer diameter, 6mm inner diameter, 17 bit resolution, SSI1, axial connector direction 1, 12V, SurTec650 surface finish.

**INC – 4H – 37.050 – 171001 – ASI1 – RFC371 – 24 – S**

Ultra High Accuracy Servo clamp stator & set-screw rotor, 37mm outer diameter, 5mm inner diameter, 17 bit resolution, asynchronous serial data, radial (250 + 250mm cable length), 24V, SurTec650 surface finish.

In the event that a custom or non-standard product is required, we will generate a part number accordingly – like the following example:-

**INC – ACME – 58 – 141002 – X3601 – AB – 12CT – SBP**

ACME custom design format, 58mm diameter, 14 bit resolution, data output over 2 revs, 0.5 to 5.0V over 360° clockwise, custom connector, 12V supply, cold temperature option, SurTec650 finish, Burn-in, leaded solder.

## 8.4 Product Ordering – Extended Range

**For most applications Extended Product Range Options are not necessary.** However, in those instances where these additional / alternative steps are mandatory or deemed necessary, please add the following Product Options to the end of the standard part number. One or more of Extended Product Range Codes may be added. Note that not all Extended Range Options apply to all sizes. Further, selection of any Extended Product Range Codes increase costs and lead-times and should only be specified if necessary.

- B** Extended thermal stress-screening (burn-in test) / bake-off
- E** Engraved serial number and part number on Stator & Rotor (rather than serial label)
- G** Very high shock & vibration mechanical arrangement
- P** Use of leaded solder (rather than RoHS compliant solder)
- V** Option for high operating pressure
- C** Conformally coated sensor faces

For cold temperature option (to -60°C operating) select **12CT** or **24CT** in Supply Voltage Product Option. (58mm IncOrder only).

For high temperature option (to 105°C operating) select **5HT** in Supply Voltage Product Option. (58mm IncOrder only).

Example of an extended part number:

**INC – 7H – 37.080 – 171001 - ASI1 – RC371 – 12 – SP**

Screw mount stator & set-screw rotor, 37mm outer diameter, 8mm inner diameter, 17 bit resolution, asynchronous serial data, radial (250 + 250mm cable length), 12V supply, Surtec650 surface finish, leaded solder.



## 9.1 Standard Cable (8-way) & High Temperature Cable (8-way)

Mating connector and tinned wires on other end.

Use this for SSI1-9, SPI1, ASI1-2 & BiSS-C comms.

Use 10-way cable for A/B Pulse comms (Section 9.2).

### Standard Cable:-

Product Option INC – CAB3 – 2 (2m long)

Product Option INC – CAB3 – 5 (5m long)

Product Option INC – CAB3 – 10 (10m long)



### High Temperature Cable:-

Product Option INC – CAB3 – 2 – HT (2m long)

Product Option INC – CAB3 – 5 – HT (5m long)

Product Option INC – CAB3 – 10 – HT (10m long)

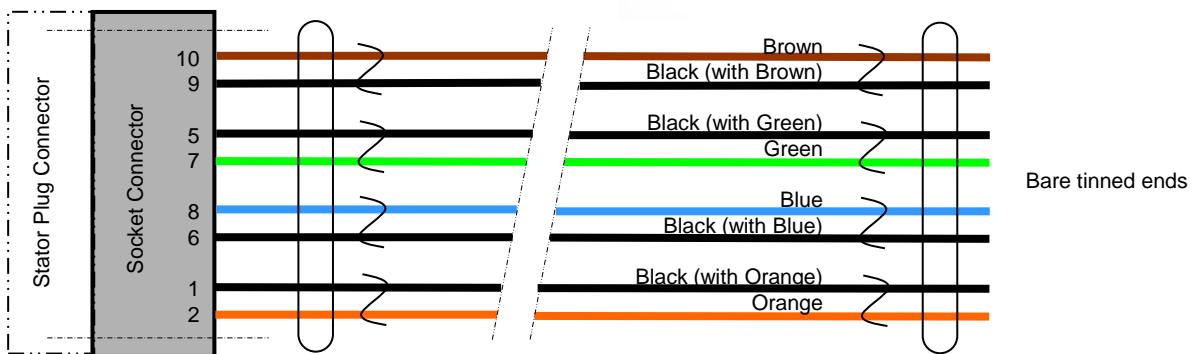

Pair No.	Colour	Connector Pin (For Info. Only)	Signal (SSI1- & SPI & BiSS-C)	Signal (ASI1-2)
1	Brown	10	V <sub>supply</sub>	V <sub>supply</sub>
1	Black	9	0V	0V
2	Black	5	Data A	Data A
2	Green	7	Data B	Data B
3	Blue	8	Clock A	Not Used
3	Black	6	Clock B	Not Used
4	Black	1	Zero Set	Zero Set
4	Orange	2	Zero Reset	Zero Reset

### Notes

- Socket Connector: Harwin DataMate J-Tek 10-way with 2 jack screws, part number M80-461-10-42
- Temperature Rating = -30 to +60Celsius or 105Celsius for -HT (High Temp.) option
- Cable diameter = 6mm nominal
- Min. flexing rad. = 76mm with a 1-off bend radius (e.g. on installation) of 20mm
- Cable length = 2, 5 or 10m (-5%) as standard
- Cable sheath & outer jacket = PVC for standard & PTFE for -HT (High Temp.) option
- Conductors = 24 AWG multi-strand copper wires, twisted pairs, overall foil shield, tinned copper drain wire
- Conductor insulation = polyethylene for standard & PTFE for High Temp. option
- For integral cable connection table see Section 4.4.4

## 9.2 Standard Cable (10-way)

Mating connector and tinned wires on other end.

Use this for ABZ comms.

If used for SSI, SPI, ASI, & BiSS-C comms, do not use connector pins 3 & 4.



- Product Option INC – CAB5 – 2 (2m long)
- Product Option INC – CAB5 – 5 (5m long)
- Product Option INC – CAB5 – 10 (10m long)

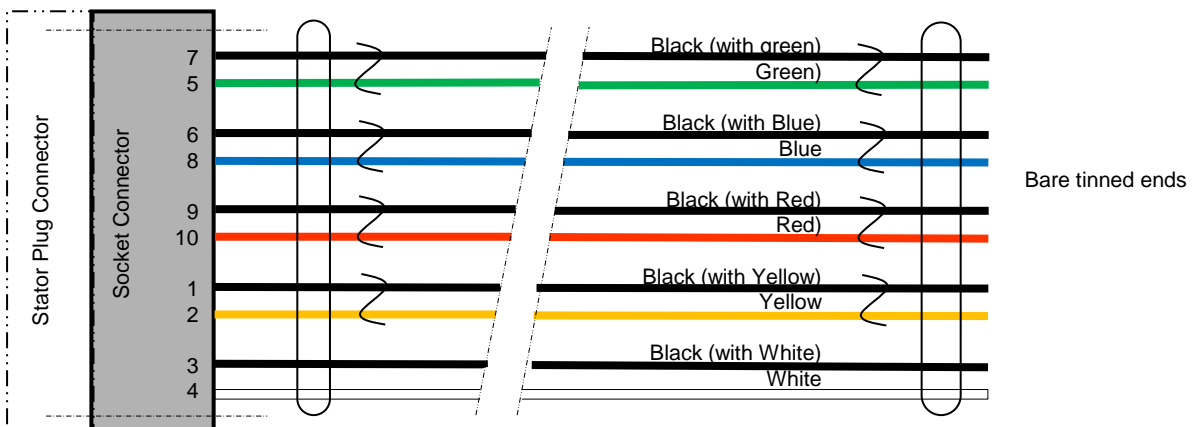

### Notes

- Cable is 10-way, 24 AWG stranded (7x32) conductors, semi-rigid PVC external insulation & jacket, 5x twisted pairs, overall foil shield (100% cover), 24AWG stranded drain tinned copper drain wire.
- Socket Connector: Harwin DataMate J-Tek 10-way with 2 jack screws, part number M80-461-10-42
- Temperature Rating = -30 to +80Celsius. UL Temperature Rating 80Celsius (UL AWM Style 2464)
- Diameter = 7.3mm
- Cable length = 2, 5 or 10m (-5%) as standard
- Min. flexing rad. = 76mm with a 1-off bend radius (e.g. on installation) of 20mm
- For integral cable connection table see Section 4.4.4.

Pair No.	Colour	Connector Pin (For Info. Only)	Signal (A/B pulses & Z Ref.)	Digital Output SSI, SPI & BiSS-C	Digital Output ASI
1	Black	7	A complement	Data B	Data B
1	Green	5	A	Data A	Data A
2	Black	6	B complement	Clock B	Not Used
2	Blue	8	B	Clock A	Not Used
3	Black	9	0V	0V	0V
3	Red	10	V <sub>supply</sub>	V <sub>supply</sub>	V <sub>supply</sub>
4	Black	1	Z Ref Set	Zero Set	Zero Set
4	Yellow	2	Z Ref. Reset	Zero Reset	Zero Reset
5	Black	3	Z	Reserved - NC	Reserved - NC
5	White	4	Z complement	Reserved - NC	Reserved - NC

## 9.3 Servo Clamp – Part Number INC-CLAMP1

For use with Servo Clamp format Stators. Servo Clamps are sometimes referred to as ‘Clamp Cleats’ or ‘Screw Clamps’. Celera Motion recommends at least 3 Clamps on each Stator in M2.5 locations equispaced on a P.C.D. of IncOder dimension (**A** + 8.00). Supplied in a pack of 3.

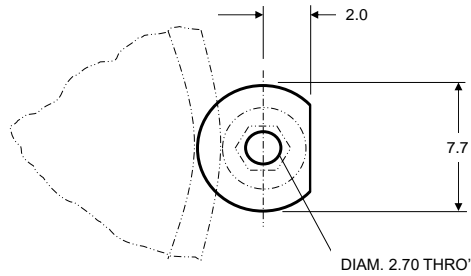

### NOTES

1. 3<sup>RD</sup> ANGLE PROJECTION
2. ALL DIMS IN mm
3. GEN. TOL. :-  
1 D.P. =  $\pm 0.2$ mm  
2 D.P. =  $\pm 0.1$ mm
4. MATL. = AL.ALLOY
5. FINISH = SURTEC650

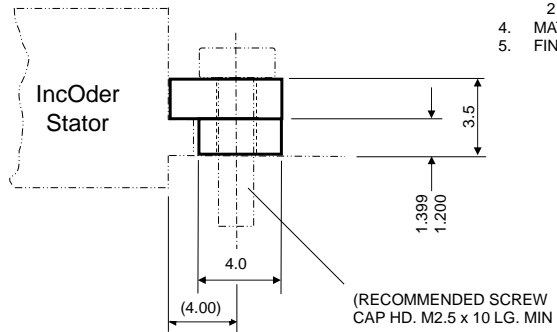

### 10.1. How do IncOders work?

IncOders work in a similar way to rotary variable transformers, brushless resolvers or synchros. The Stator receives DC power and produces a low power AC electromagnetic field between the Stator & Rotor. This field is modified by the Rotor depending on its angle. The Stator senses the resulting field and outputs the rotation angle as an analogue or digital signal. Unlike resolvers, IncOders use laminar circuits rather than wound wire spools. This technology enables IncOder's compact form, low mass, low inertia and high accuracy without high precision installation.

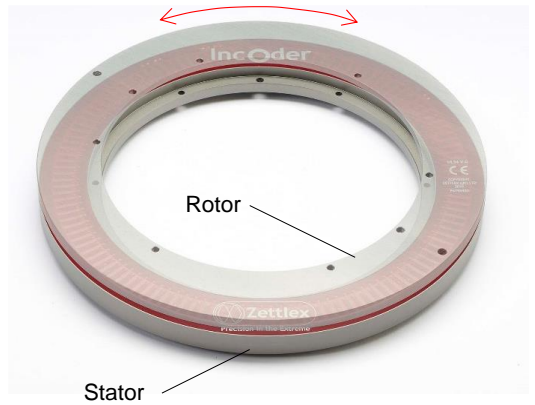

### 10.2. Is IncOder measurement truly absolute for absolute output devices?

Yes. Measurement will be the same before and after power interruption. No motion is needed at start up.

### 10.3. Does measurement performance vary with Rotor concentricity?

Resolution, repeatability & accuracy (linearity) will be as specified, provided Rotor concentricity is within specified limits. One might expect accuracy to degrade significantly with concentricity, but IncOders use the full faces of Rotor & Stator, so errors are nulled by diametrically opposing factors. This is different to other encoder technologies – notably optical or capacitive devices - where performance depends on tightly controlled concentricity.

### 10.4. Can IncOders be used outside the stated operating temperature limits?

Operating temperature limits are set by some of IncOder's electronic parts rather than the basic technique. Standard IncOders are rated -40 or 85°C operation and with a cold option (Product Options 12VCT & 24VCT) for -60°C operation (58mm IncOder only). IncOders can be used outside these limits following qualification by the user. At temperatures >85°C the duration of any elevated temperature should be minimized. At temperatures at or below the stated lower limit, it is recommended to leave the unit powered or allow an extended powered period (>1 minute) before operation.

### 10.5. What happens if the Rotor or Stator get wet or dirty?

Measurement performance is unaffected by humidity, condensation, dirt, dust, oil, mud or sand. All IncOders will survive temporary immersion to depths of 1m in salt or fresh water. Where frequent exposure to liquids, or immersion, is part of the operating environment, units with connections type AFL or VFL should be used.

### 10.6. How can an IncOder be calibrated?

Calibration is only relevant for some ultra high accuracy applications such as astronomical telescopes. Readings from an IncOder are stored and compared to a reference in a look-up table in the host system. Such an arrangement will negate any inaccuracy due to inherent non-linearity or installation tolerances. Resolution & repeatability are unaffected by calibration. For higher accuracy, please see IncOder Ultra Range.

### 10.7. At what Baud rate can the data interface operate at and does this effect cable length?

The longer the transmission distance (Cable Length), the slower the recommended Baud Rate. This table shows recommended Baud Rates vs. Cable Length.

Baud Rates For Data Transmission				
Cable Length (m)	<30	<60	<120	<250
Baud Rate	<400 kHz	<300 kHz	<200kHz	<100 kHz

### 10.8. Are IncOders affected by magnets?

No. Magnets produce DC fields. IncOders use AC electro-magnetic fields at a highly specific frequency.

### 10.9. Are IncOders suitable for use in harsh electromagnetic fields?

Yes. Many IncOders are used near powerful sources of electromagnetic noise such as motors or transformers. IncOder's aluminium housing produces a Faraday cage effect around the internal electronics and the technology is designed so that incoming, far-field radiation is self cancelling or filtered out.

### 10.10. Do IncOders produce electromagnetic emissions?

Radiated emissions are tiny and limited to the IncOder's internal sensor faces. The IncOder housing has a Faraday cage effect. IncOders are often used in proximity to sensitive devices such as navigation aids.

### 10.11. What if we need to earth the IncOder casing?

Some applications such as fighting vehicles and aircraft require the IncOder casework to be electrically earthed. Some IncOder housing finishes are hard-anodized which is non-conductive. A connection can be made using an earth strap with a crinkle washer which penetrates the anodized surface. Alternatively, remove the anodized surface in the immediate vicinity of the strap (usually located using one of the attaching screws) using a file or abrasive. Alternatively, conductive finishes such as Surtec650 may be specified from the Extended Product Range (standard for 37 and 58mm products).

### 10.12. Does the Rotor need electrical earthing?

No. Some capacitive devices require the rotating shaft to be electrically connected to earth so as to avoid electrostatic interference. There is no such requirement with IncOder.

### 10.13. Does measurement performance vary with Rotor to Stator gap?

Resolution, repeatability & linearity will be as specified, provided gap is to specified tolerances. Within limits, the IncOder's measurement resolution & repeatability are independent of gap. If gap tolerance is increased from  $\pm 0.35\text{mm}$  to  $\pm 0.50\text{mm}$  the *guaranteed* measurement non-linearity will double. For example, if a 250mm IncOder has a gap tolerance of  $\pm 0.50\text{mm}$  (rather than the specified  $\pm 0.35\text{mm}$ ) the *guaranteed* linearity will increase from  $\pm 40$  arc-secs to  $\pm 80$  arc-secs. Gap tolerances are most easily achieved using Set Screw or Shaft Clamp Rotors.

### 10.14. Do IncOders carry out self checks or Built-In-Test (BIT)?

Yes. If BIT shows an internal error then an error signal is generated. The BITs include continuity/damage, presence of Rotor, in-range Rotor, gross electromagnetic malfunction, window watchdog timer, power on reset, power brownout reset, timeouts for clock input, read/write and internal flash data memory value checks.

### 10.15. Do IncOders outgas?

IncOder housings are hard-anodized or Surtec finished aluminium which produce no outgassing. The epoxies and other materials used inside the devices comply with NASA's classification of low outgassing materials for spacecraft with TML of  $<1\%$  and CVM of  $<0.1\%$  measured at  $125^\circ\text{C}$  over 24 hours in vacuum according to ASTM E-595-90. IncOders are successfully used with sensitive optical devices without residues from the IncOder affecting the lenses.

### 10.16. How can we specify a custom IncOder variant?

Use this document as a basis and specify any differences. Preferably, a standard outer diameter 'A' dimension (i.e. 37, 58, 75, 90mm etc.) and a proportionate inner diameter should be used. This enables us to use regular sensor components with an alternative mechanical format.

### 10.17. What's the largest IncOder you can build?

595mm outer diameter is the largest size which can be found in our Maxi Product series product guide. Contact Celera Motion or your local representative for larger sizes.

### 10.18. Do IncOders require an Export License?

Not usually. IncOders are exempt from Annex I to Council Regulation (EC) No. 428/2009, as amended [EU Dual-Use List] and only require an export license if the diameter is greater than or equal to 1000mm or accuracy is  $<1$ arc-second. No standard products are in this class.

### **10.19. How does Celera Motion manage the obsolescence of electronic components?**

Celera Motion has detailed obsolescence policies and procedures as part of our Quality Management System. Generally, our policy is only to use electronic components which are widely used; available from a variety of sources and have low likelihood of obsolescence. In the event of an electronic component becoming obsolete we typically select, specify and, if necessary, qualify a suitable form, fit & functional alternative.

### **10.20. Can IncOders be used submerged in oil or water?**

Yes. All units can be used in mineral oil. Use integral axial cable connections (58mm only) for submersion in water together with Extended Range Product Option C. If submersion is at depth then also specify Extended Range Product Option C (58mm only). If necessary, contact Celera Motion for further information.

### **10.21. Does the accuracy of IncOders improve if the range is reduced?**

Yes. Repeatability is unaffected but accuracy – in other words, linearity - improves as the range reduces. This can be advantageous in some applications where the range of motion is restricted, such as elevation controls in pointing devices which are often <90°. Contact Celera Motion for further information.

### **10.22. Can we accurately calculate speed using an IncOder?**

Yes. There are various approaches and the optimal approach depends on the nature of your application and how accurately speed is to be measured. The first option is to use an IncOder with A/B pulses. The second option is to use a device with an absolute angle output such as SPI, BiSS-C or SSI, and where SPI1, BIS3 or SSI4 product options are particularly advantageous. The approach for this second option is detailed in a separate document - please refer to Zettlex IncOder App Note – Calculating Speed. You can find this in the IncOder section of our web-site ([www.celeramotion.com](http://www.celeramotion.com)) or ask your local Celera Motion representative for a copy.

### **10.23. Does current consumption depend on supply voltage?**

No - because we use linear voltage regulators in the IncOder stator.

**Revision History**

- o New document

While Zettlex provides application assistance personally, through our literature, web-site and partners, it is the customer's responsibility to determine the suitability of the product in the application.

Specifications may change without notice. Quoted data is derived from test, analysis or design similarity. The information provided by Zettlex in this Product Guide is believed to be accurate and reliable as of this printing, however, Zettlex assumes no responsibility for its use.

**WARRANTY/REMEDY**

Zettlex warrants goods of its manufacture as being free of defective materials and faulty workmanship for 1 year from date of purchase. Zettlex standard product warranty applies unless agreed otherwise by Zettlex in writing. Please refer to Zettlex or local representative for warranty details. If warranted goods are returned to Zettlex during the warranty period then Zettlex will repair or replace, at its option, without charge those items that it finds defective. The foregoing is the buyer's sole remedy and is in lieu of all other warranties, expressed or implied, including those of merchantability and fitness for a particular purpose. In no event shall Zettlex be liable for consequential, special or indirect damages.



**WARNING. PERSONAL INJURY.**

Do not use these products as safety or emergency stop devices or in any application where failure of the product could result in personal injury. Failure to comply to these instructions could result in death or serious injury.



**WARNING. PERSONAL INJURY.**

Do not use these products in any application where there is the potential for combustion or explosion with flammable gases, dust or liquids. Failure to comply to these instructions could result in death or serious injury.

All products available via your local reseller or from the Celera Motion web-site at  
<https://www.celeramotion.com>

Zettlex (UK) Ltd.  
Faraday House  
Barrington Road  
Foxton  
Cambridge  
CB22 6SL  
United Kingdom  
Tel [+44] 01223 874444  
Fax [+44] 01223 874111  
Email [info.zettlex@celeramotion.com](mailto:info.zettlex@celeramotion.com)  
[www.celeramotion.com](http://www.celeramotion.com)